

THE DANISH
INGOLF-EXPEDITION.

VOL. IV, PART 9.

CONTENTS:

S. G. HEDING: HOLOTHURIOIDEA.

PART I.

APODA. — MOLPADIOIDEA. — GEPHYROTHURIOIDEA.

PUBLISHED AT THE COST OF THE GOVERNMENT

BY

THE DIRECTION OF THE ZOOLOGICAL MUSEUM OF THE UNIVERSITY.

2352

~~10780~~



COPENHAGEN.

H. HAGERUP.

PRINTED BY BIANCO LUNO A/S.

1935.

K.B.I.N.-I.R.Sc.N.B.



THE DANISH INGOLF-EXPEDITION

VOLUME IV.

9.

HOLOTHURIOIDEA.

PART I.

APODA. — MOLPADIOIDEA. — GEPHYROTHURIOIDEA.

BY

S. G. HEDING.

WITH 8 PLATES, XXI FIGURES AND TWO CHARTS IN THE TEXT,
AND A LIST OF STATIONS.

~~10780~~

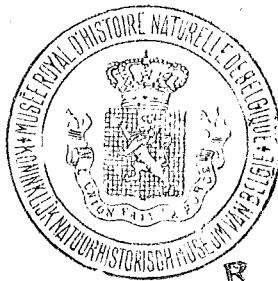

COPENHAGEN.

PRINTED BY BIANCO LUNO A/S

1935.

Contents.

I. APODA.

	Page		Page
Family: <i>Chiridoidea</i>	7	Family: <i>Myriotochidae</i>	18
Genus: <i>Chiridota</i>	7	Genus: <i>Myriotochus</i>	19
— <i>laevis</i>	8	— <i>rinkii</i>	19
— <i>pellucida</i>	13	Subgenus: <i>Oligotrochus</i>	22
— <i>spirourma</i>	15	— <i>vitreus</i>	23
— <i>groenlandica</i>	16	Genus: <i>Acanthotrochus</i>	24
Genus: <i>Achiridota</i>	16	— <i>mirabilis</i>	24
— <i>profunda</i>	16	Genus: <i>Trochoderma</i>	27
— <i>ingolfi</i>	17	— <i>elegans</i>	27

II. MOLPADIOIDEA.

	Page		Page
Ordo: <i>Molpadioidea</i>	33	<i>Trochostoma boreale</i>	60
Family: <i>Molpadiidae</i>	34	Family: <i>Caudinidae</i>	61
Genus: <i>Molpadia</i>	35	Genus: <i>Caudina</i>	62
Subgenus: <i>Paramolpadia</i>	37	— <i>arenata</i>	62
— <i>diploa</i>	38	Genus: <i>Haplodactyla</i>	64
Genus: <i>Eumolpadia</i>	41	— <i>albicans</i>	65
— <i>asaphes</i>	42	— <i>mediterranea</i> (Textfig. XXI)	67
Genus: <i>Ankyroderma</i>	44	Family: <i>Eupyrgidae</i>	67
— <i>jeffreysii</i>	45	Genus: <i>Eupyrgus</i>	68
— <i>affine</i>	47	— <i>scaber</i>	69
Genus: <i>Trochostoma</i>	51	Genus: <i>Paratrochostoma</i>	72
— <i>thomsonii</i>	52	— <i>spiniferum</i>	72
— <i>arcticum</i>	58		

III. GEPHYROTHURIOIDEA.

	Page
Ordo: <i>Gephyrothurioidea</i>	77
Family: <i>Gephyrothuriidae</i>	77
Genus: <i>Molpadiodemas</i>	77
— <i>acaudum</i>	78

INTRODUCTION

The present paper deals with the Synaptids¹⁾, the Molpadids and the molpadid-like Holothurians collected by the "Ingolf" expedition. Besides these are included the specimens collected by the Danish research-steamers "Thor" and "Dana" as well as a few collected by Ad. S. Jensen on board the "Michael Sars" and the specimens from Greenland kept in the Zoological Museum of Copenhagen.

The material at hand is of great systematical interest, as besides all the species known from the area dealt with, it contains eight new species, two of which represent new genera. The specimens are so nicely preserved that it has been possible to base a usable classification of the laevis-like Chiridotids, the Myriotrochids and the Molpadids on them. The collections include the following species:

I. *Chiridotidae*

- Chiridota laevis (Fabricius)
- pellucida (Vahl)
- spirourna n. sp.
- groenlandica n. sp.
- Achiridota profunda n. sp.
- ingolfi n. sp.

II. *Myriotrochidae*

- Myriotrochus rinkii Steenstrup
- Oligotrochus vitreus (Sars)
- Acanthotrochus mirabilis Danielssen & Koren
- Trochoderma elegans Théel

III. *Molpadiidae*

- Molpadia (Paramolpadia) diploa n. sp.
- Eumolpadia asaphes n. sp.
- Trochostoma thomsonii Danielssen & Koren
- arcticum (v. Marenzeller)
- boreale (M. Sars)

¹⁾ The term "Synaptids" is used for the three families *Synaptidae* — *Chiridotidae* — *Myriotrochidae* i. e. for all three families of the Ordo: *Apoda*. This is thought to be most practical.

IV. *Caudinidae*

Caudina arenata (Gould)

Haplodactyla albicans (Théel)

V. *Eupyrgidae*

Eupyrgus scaber Lütken

Paratrochostoma spinifer n. sp.

VI. *Gephyrothuriidae*

Molpadiodemas acaudum n. sp.

Besides being of systematical value, the material at hand is of considerable zoogeographical interest, but at present few conclusions only can be drawn on this point, as our present knowledge of the Molpadids from other localities is too insufficient.

As to the Synaptids, it is interesting that the two littoral species *laevis* from Greenland and *pellucida* from Norway and Iceland are particularly different, and furthermore differ much from the abyssal species *groenlandica* and *spirourna* from nearly the same localities. Further, it should be pointed out that a more primitive Synaptid like *Myriotrochus rinkii* Stp., which is littoral too¹⁾, may be found in both the *laevis* and the *pellucida* localities, besides in the more arctic neighbouring localities.

As the present report is merely systematical and zoogeographical, only little stress is laid on anatomical details, which are of no value to the classification. The specimens dealt with are however mainly characterized by anatomical details, so that large parts of the descriptions and figures seem, as it were, to be made for comparative anatomy. When dealing with so intricate specimens as Apelete Holothurians it is impossible to distinguish between pure systematic and comparative anatomy.

In this place I want to express my best thanks to the Management of the Zoological Museum, which has placed this important material in my hands, and more particularly to Dr. Mortensen, who from the beginning to the end has followed this work with the kindest interest.

¹⁾ The "Godthaab" expedition has found a few *Myriotrochus rinkii* Stp. in depths of about 800 m. Cf. Mortensen: Echinoderms of the Godthaab expedition 1932.

I. Apoda.

Family Chiridotidae Östergren 1907.

Diagnosis: Synaptids with peltato-digitate tentacles, calcareous ring well developed with no traces of a cartilaginous ring. Stone-canal single and polian vesicles of varying number, often increasing in number with the size of the specimen. Intestine usually with a loop and on the mesenteries normally ciliated funnels. The ciliated funnels are rather varying, even in the single specimen, nevertheless they are of high classificatory value. Deposits, when present, always wheels, usually in groups, though in some genera scattered all over the body-wall. The wheels normally with six spokes. Beside the wheels, there may be rods of different shape; anchors and anchor-plates are however always absent.

Remarks: The family *Chiridotidae* in the present collections is represented by two genera, *Chiridota* and *Achiridota*. Probably a third new genus is represented, but as but a single specimen is at hand, it has previously been referred to the genus *Achiridota* and described as *Achiridota? ingolfi* n. sp.

No doubt it is most reasonable to follow Östergren in his division of the Synaptids into three families. These are distinctly different and apparently no real intermediate species or genus has been found. Probably, it will be most reasonable to divide the *Chiridotidae*, too, into two groups, which like the two groups of the *Synaptidae*, the *Micrournae* and the *Heterournae*, may be regarded as sub-families. The former, the *Asigmoinae*, quite naturally, comprises the genera *Chiridota*, *Polycheira*, *Achiridota* and *Toxodora*, and the latter, the *Sigmoinae*, comprises the genera *Taeniogyrus*, *Trochodota* and *Scoliodota*.

Genus *Chiridota* Eschscholtz 1829.

Of the genus *Chiridota* two different species were previously known from the North Atlantic, *Ch. laevis* (Fabr.) and *Ch. pellucida* (Vahl), but Östergren and Clark have not distinguished between these two species.

The collections at hand include up to three hundred specimens, apparently all *laevis*, but a careful examination has shown that it is possible to distinguish between four different species, *laevis* (Fabricius) *pellucida* (Vahl), *spirourna* n. sp. and *groenlandica* n. sp.

Besides these four species a fifth is known from the North Atlantic, *abyssicola* v. Marenzeller. It is true that it is found farther south than the others, but as it is found in great depths, there is good reason for supposing that it may be found in the area explored by the "Ingolf" expedition.

In 1908 Clark united this species with *laevis*, but there is no reason for this. Judging from the locality

it might be supposed to be synonymous with either *pellucida* or *spirourna*; of these species *pellucida* is however pronouncedly littoral, and the general appearance of *spirourna* and *abyssicola* does not indicate any closer relation between them. The North Atlantic species of *laevis*-like Chiridotas may in practice be separated in the following way:

1. Littoral species	2
Abyssal species	3
2. Ciliated funnels with a thin collar	<i>laevis</i>
Ciliated funnels with a thick collar	<i>pellucida</i>
3. Southern species	<i>abyssicola</i>
Northern species	4
4. Ciliated funnels in the middle of the body large and short-stalked	<i>spirourna</i>
Ciliated funnels in the middle of the body small and long-stalked	<i>groenlandica</i>

***Chiridota laevis* (O. Fabricius).**

Pl. I, fig. 8, Pl. III, fig. 13.

Holothuria laevis O. Fabricius. 1780. Fauna Groenlandica pag. 353.

Chirodota laeve Lütken 1857. Grønlands Echinodermata pag. 16.

Chiridota laevis Clark 1908. The Apodous Holothurians pag. 28, 119.

— — Heding 1928. Synaptidae pag. 287.

— — — 1931. Ueber die Synaptiden des Zool. Mus. zu Hamburg pag. 678.

Localities:

- I. The west coast of Greenland from the South to Disko (i. e. from: Nanortalik — Julianehaab — Igalikofjord — Narssak harbour — Frederikshaab — Godthaab — Agpamiut — Amitsuarssuk (Godthaab Fjord) — Kapisilik — Sukkertoppen — Holstensborg — Egedesminde — Godhavn) 255 specimens.
- II. The east coast of North America (i. e. from: Eastport Maine and Fundy Bay) 6 specimens.

This species is not included in the collections of the "Ingolf" expedition, but as it is said to be distributed throughout the northern Atlantic, and furthermore as the "Ingolf" collections include several species closely related to it, and only separated from it with difficulty, it will be natural to include a closer description of this interesting, and hitherto rather unsatisfactorily described species.

Of the large collection of *C. laevis* at hand, each specimen has been carefully examined, and more than half of them dissected.

The normal length of a mature specimen is 5—8 cm (there are some few specimens which measure upwards of 16 cm). The colour is usually yellowish white, but may be reddish or quite brown. All over the body, and especially on the tentacles and the oral disk some small reddish-brown pigment spots are found; some specimens are more densely spotted with brown than others. In each of the three dorsal interradia a single row of white papillæ is seen (also with the unarmed eye), which are due to heaps of wheels. The number of spots in each row may vary much. In some specimens there may be more than 75, but there are usually 30—50.

The wheel-papillæ are not of equal size, and rather often every second is much larger than the others, but in other specimens large and small papillæ are found lying in casual order.

The number of tentacles is twelve, but in about 4 per cent. of the examined specimens there are 13 and in about 1 per cent. there are but 11. The normal arrangement of the tentacles is that there are two tentacles in the dorsal and in each of the two ventral interradii, and three in each of the two lateral interradii. When there are more than twelve tentacles present, the extra one is always found in one of the two ventral interradii, alternating in the left and the right one. When there are only 11 tentacles in a specimen, it will always be one of the lateral ones which is lacking. Due to the connection between tentacles and calcareous ring, variations in the number of tentacles will always cause a corresponding one in the number of pieces of the calcareous ring.

The tentacles are peltato-digitate having usually 5—7 pairs of digits, but the number may vary from a single pair and up to nine pairs; the number is obviously varying in conformity with the size of the specimen. It is peculiar that very often the dorsal tentacles of a specimen has one or two pairs of digits fewer than the ventral ones, but this is not the general rule, as some few specimens are found with an equal number of digits on all tentacles, and a specimen with six pairs of digits on the ventral and seven on the dorsal tentacles is even recorded. The digits are always free of each other, but the tentacles proper are united at the base by a low web.

The calcareous ring normally consists of twelve pieces, the five radial of which are perforated for the passage of the radial nerves. The shape of the calcareous ring and the muscular impressions on its exterior side is very constant (Pl. III, fig. 13). A cartilaginous ring is lacking.

The ring-canal is large, and supplied with 5—30 polian vesicles. Usually the number of polian vesicles increases with the size of the specimens, but this is not quite constant. There is a single stone-canal and the madreporite is varying in shape. The intestine is supplied with a large loop. It is fastened by the normal three mesenteries as far as to the rectum, but the rectum itself, which in many other Synaptids is fastened to the body-wall by numerous threads, is in this species fastened to the most posterior ends of the longitudinal muscles (Pl. I, fig. 8).

The specimens of *laevis* do not appear to be mature before they are about 4—5 cm long, but then the gonads are also exceedingly voluminous, and much branched. The gonads open, usually on a little wart in the dorsal interradius close behind the tentacles. In some specimens the genital papilla is exceedingly large, and in others it is almost rudimentary. The sexes appear to be separate, but it is not possible to ascertain this with certainty. Some of the specimens are evidently purely male or purely female, but others have apparently both eggs and sperma in their gonads, some in the same tubes, and others in separate tubes. The ripe eggs measure in the gonad-tubes about 0.350 mm in diameter, but when taken from the oviduct they are 0.420 mm large.

Ciliated funnels are found on all three mesenteries, and they are often present in surprisingly large numbers. The comparative study of funnels from all three mesenteries, as well as from the two ends of more than a hundred well preserved specimens, has shown that the funnels of this species vary much in size and shape. The most typical funnels, and also those of the most constant shape, are found in the anterior

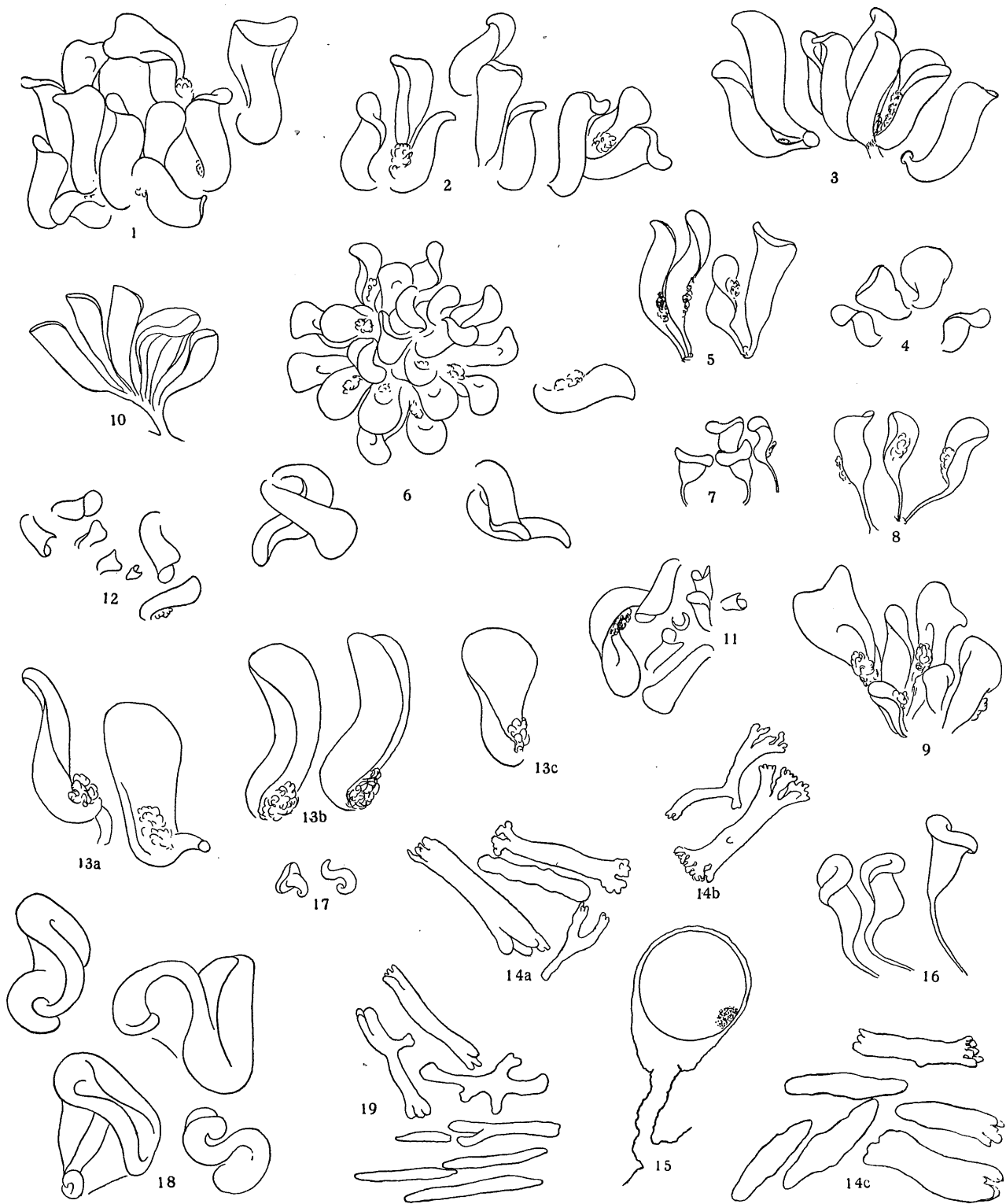

Fig. I. 1—15. *Chiridota laevis*. 1—12 drawn after free funnels by means of a preparation microscope. 1—4. Ciliated funnels of a 14 cm large specimen. 1 from right ventral mesentery, 2 from left ventral mesentery, 3 from dorsal mesentery, 4 from posterior end of specimen. 5—7. Ciliated funnels of a specimen from Agpamiut. 5 from dorsal mesentery, 6 from right ventral mesentery, 7 from posterior end of specimen. 8. Ciliated funnels of a specimen from Agpamiut, right ventral mesentery. 9. Ciliated funnels of a specimen from Godthaab, right ventral mesentery, anterior end. 10. Ciliated funnels united in a distinct cluster from the dorsal mesentery of a specimen from Agpamiut. 11. From the same specimen, left mesentery, anterior end, 12. From the same specimen left mesentery posterior end. 13 a—c. Ciliated funnels of a specimen from Agpamiut, drawn from a balsam preparation, by means of a monocular microscope. 14 a—c. Rods from the tentacles of three specimens. 15. A parasite from the body-cavity of a specimen from Agpamiut. 16. *Chiridota groenlandica* ciliated funnels from the anterior half of the specimen. 17—19. *Achiridota ingolfi*. 17. Ciliated funnels drawn by means of a preparation microscope, with the same magnification as used in *laevis*. 18. The same drawn after a preparation mounted in balsam, drawn with a monocular microscope with a magnification of $\frac{220}{1}$. 19. Tentacle-rods from the same specimen.

end of the specimens, on the ventral and often on the lateral mesentery too. While the ciliated funnels of the anterior end of these two mesenteries are rather alike, those on the dorsal mesentery may be somewhat larger and usually of another shape. In the most posterior ends of the specimens there are only few ciliated funnels, and these are always distinctly smaller than the funnels from the anterior end, and furthermore they are often of a somewhat different shape.

Textfigure I, 1—4, shows the funnels of a specimen about 14 cm long. The funnels from the ventral and lateral mesentery (Textfig. I 1—2) measure 500—600 μ in length. They are usually unstalked, not united into clusters, and have a more or less developed curved "collar", which in no case is thicker than the walls of the funnel. On the dorsal mesentery (Textfig. I, 3) the funnels are nearly all without a curved "collar", they are often faintly stalked and may be united into small clusters. In the posterior end of the specimen the funnels are distinctly smaller than more anteriorly, and their "collar" is comparatively larger (Textfig. I, 4).

Though the funnels described represent the most typical form of ciliated funnels in mature specimens, specimens with funnels of a rather different shape are frequently found. Textfig. I, 6, shows four groups of funnels from the ventral mesenteries of a specimen from Agpamiut. Here the funnels are spread all over the mesentery, though they are more crowded close to the body-wall. Normally, they are placed either singly or in couples on the mesentery, but some large groups as the figured one may often be found. As will easily be seen, when such a group of funnels is removed or watched from the opposite side of the translucent mesentery, all funnels of such a group are placed on a common short stalk, or perhaps better, on a common low wart. The funnels from the dorsal mesentery of this specimen are all collected close to the body-wall, and they differ from the ventral funnels in being rather longstalked (Textfig. I, 5). The anal funnels are as in the first mentioned specimen much smaller than the others, but contrary to what is the case with the "anal-funnels" of other specimens, they are exceedingly long-stalked (Textfig. I, 7). Though the ventral and lateral funnels are usually unstalked or short-stalked, some of the specimens from Agpamiut have well-developed long-stalked funnels on these two mesenteries too (Textfig. I, 8). The fact that actually stalked clusters occur in this species too is evident from the preparation represented in textfig. I, 10, from the dorsal mesentery of a specimen from Agpamiut.

As far as can be judged from the material at hand, only a single or very few funnels are developed in the young *lævis* just metamorphosed, and these first funnels may be found on the most anterior part of the mesenteries, and perhaps only on the dorsal mesentery. While the specimens grow, these first funnels very soon attain their normal size, and meanwhile other funnels are developed. This assumption agrees with the fact that in small specimens, about 2 cm long, only few normal-sized funnels are found on the most anterior part of all three mesenteries (Textfig. I, 11). In the posterior half of such small specimens only young developmental stages of funnels (Textfig. I, 12) are found, and in the most posterior end funnels are almost totally lacking. — In larger specimens of about 5—6 cm with well developed gonads, small funnels are rarely found on the dorsal mesenteries, on which there is an abundance of large funnels, and in 8—9 cm long specimens small funnels are usually lacking in the anterior half of the specimen.

It seems natural to assume that in wholly grown up specimens the anal funnels may be of the same size as those found more anteriorly. This need not be the case, however, the anal funnels of the largest speci-

mens at hand are not only distinctly smaller than the more anterior ones, but they are of a shape quite different from that of the half-developed funnels found in other specimens, and thus there is no reason for supposing that they may ever grow into normal-sized funnels.

Of calcareous deposits only six-rayed wheels and more or less branched tentacle-rods are found. The

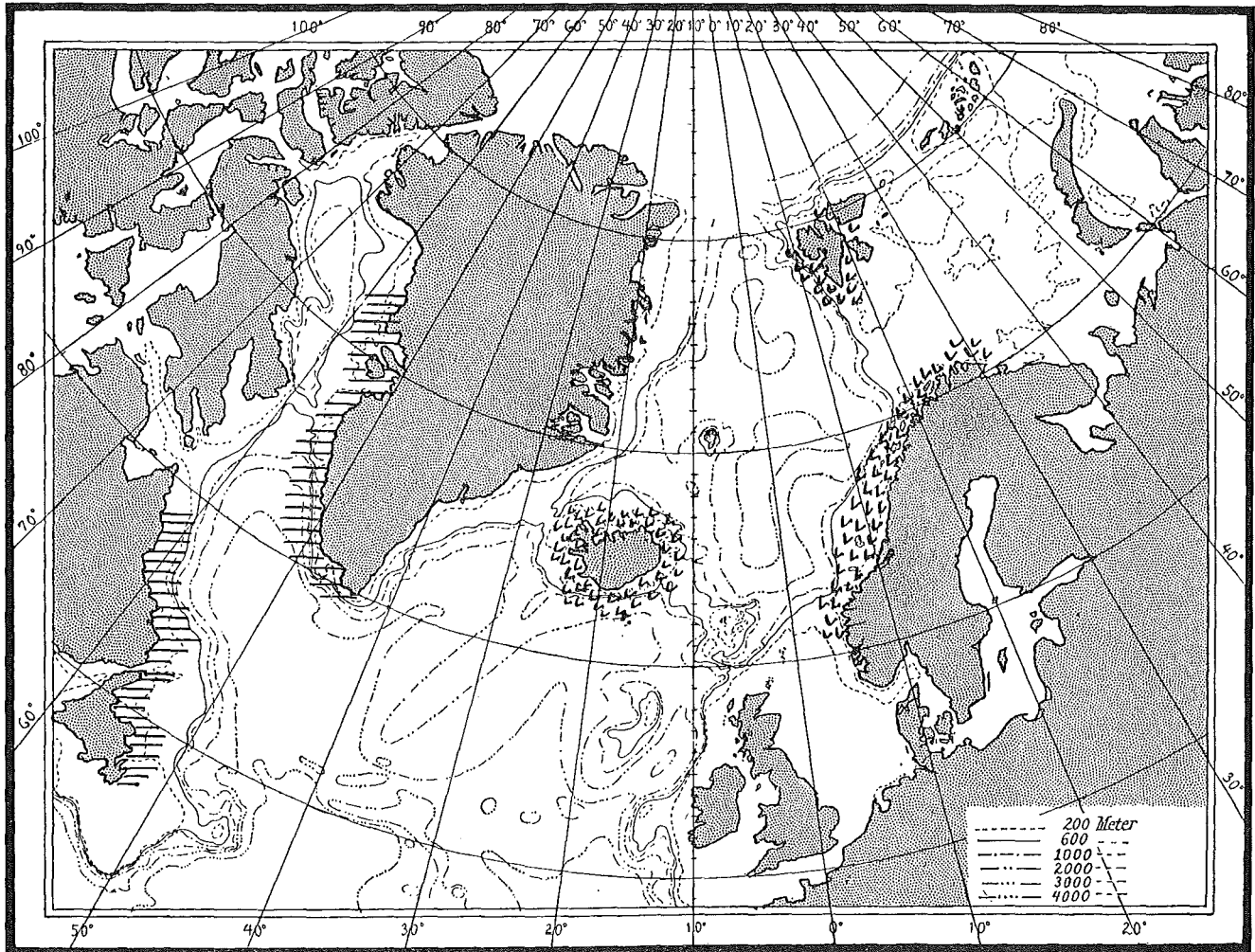

Ch. laevis



Ch. pellucida

Map. 1. Distribution of *Ch. laevis* and *Ch. pellucida*.

wheels are confined to the "wheel-papillae" of which there may be more than 250 in a single specimen. The number of wheels in each papilla may vary from half a score to over a hundred. The wheels will always be largest in the periphery of the papillae, where they may measure 90—110 μ in diameter; in the centre of the papillae the wheels may be 70—90 μ large, 90 μ if the wheels from the periphery are 110 μ large, and 70 μ if the latter are only 90 μ in diameter.

As far as may be seen tentacle-rods are always present in the dorsal tentacles, though they may be lacking in the ventral ones, and it is an established fact that there will always be many more rods in the dorsal

tentacles than in the ventral ones. This is very interesting, as it may probably be due to the same cause as occasions that the wheel-papillae will always be most numerous on the dorsal side of the specimen (cf. the presence of rods in the most anterior end of the dorsal inter-ambulacra of *Chiridota pacifica* Heding).

The shape of the rods (Textfig. I, 14 a—e) is highly varying. Some are merely pointed staves and others are branched bodies.

Chiridota laevis (O. Fabricius) as described here, is a characteristic West-Greenland littoral species, which is not recorded with certainty from other places than along the West-Greenland and East Canadian coasts from Disko to Newfoundland and Fundy Bay.

The greater part of the records of *Ch. laevis* from other localities may be erroneous and due to confusion with other, though closely allied, species. Such mistakes may easily be made, as the systematical characters of this group of Synaptids are exceedingly few, very varying within the single species, and highly difficult to examine. Furthermore the real *laevis* from Greenland has hitherto never been described in details.

In some of the specimens from Agpamiut, a number of Gregarins are found. Due to the determination of Mr. Holger Madsen, they are *Lithocystis brachycercus* Pixell Goodrich (cfr. Textfig. I, 15) and *Urospora chiridotae* Dogiel.

Chiridota pellucida (Vahl).

Pl. III, fig. 11.

Holothuria pellucida Vahl 1806. Zool. danica 4 Fasc. pag. 17, Tab. 135 f. 1.

Chirodota pellucida M. Sars 1861. Oversigt af Norges Echinodermer, pag. 124—39, Pl. 14—16.

Chiridota laevis Östergren 1902. The Holothurioidea of Northern Norway, pag. 13.

— — part. Clark 1908. The Apodous Holothurians, pag. 119.

— — — Heding 1931. Ueber die Synaptiden des Zool. Mus. zu Hamburg, pag. 678.

Localities:

Øfjord, Iceland. Möller	1 Sp.
Seljasund, Iceland. Jónsson ²⁹ / ₆ 97; 50 m.	11 -
Berufjord, Iceland. "Diana" St. 25 b ¹⁷ / ₇ 1900; 11 m.	22 -
Norway 1866, Bergens Museum	1 -
— Grøtø, Bergens Museum	3 -
— Porsangerfjord, Bergens Museum	3 -
— Røst, Bergens Museum	1 -

Exteriorly this species bears a close resemblance to *Ch. laevis* Fabr. It has 12 tentacles, each with c. 6 pairs of digits. The calcareous ring is typically "*Chiridota*"-shaped and thus very much like that of *Ch. laevis*, even if slightly different (Pl. III, fig. 11). The five radials are perforated for the nerves. There are 6—12 polian vesicles and a single stone canal. The alimentary canal has a large loop and the gonads are distinctly branched, opening with a little papilla close to the dorsal tentacles.

The ciliated funnels are remarkable. In the specimens from Seljasund, those from the anterior end of the specimens are large and irregular and supplied with a voluminous thick collar (Textfig. II, 1), and those from the posterior end (Textfig. II, 2) are small nice funnels with a very thick collar. In the small specimens

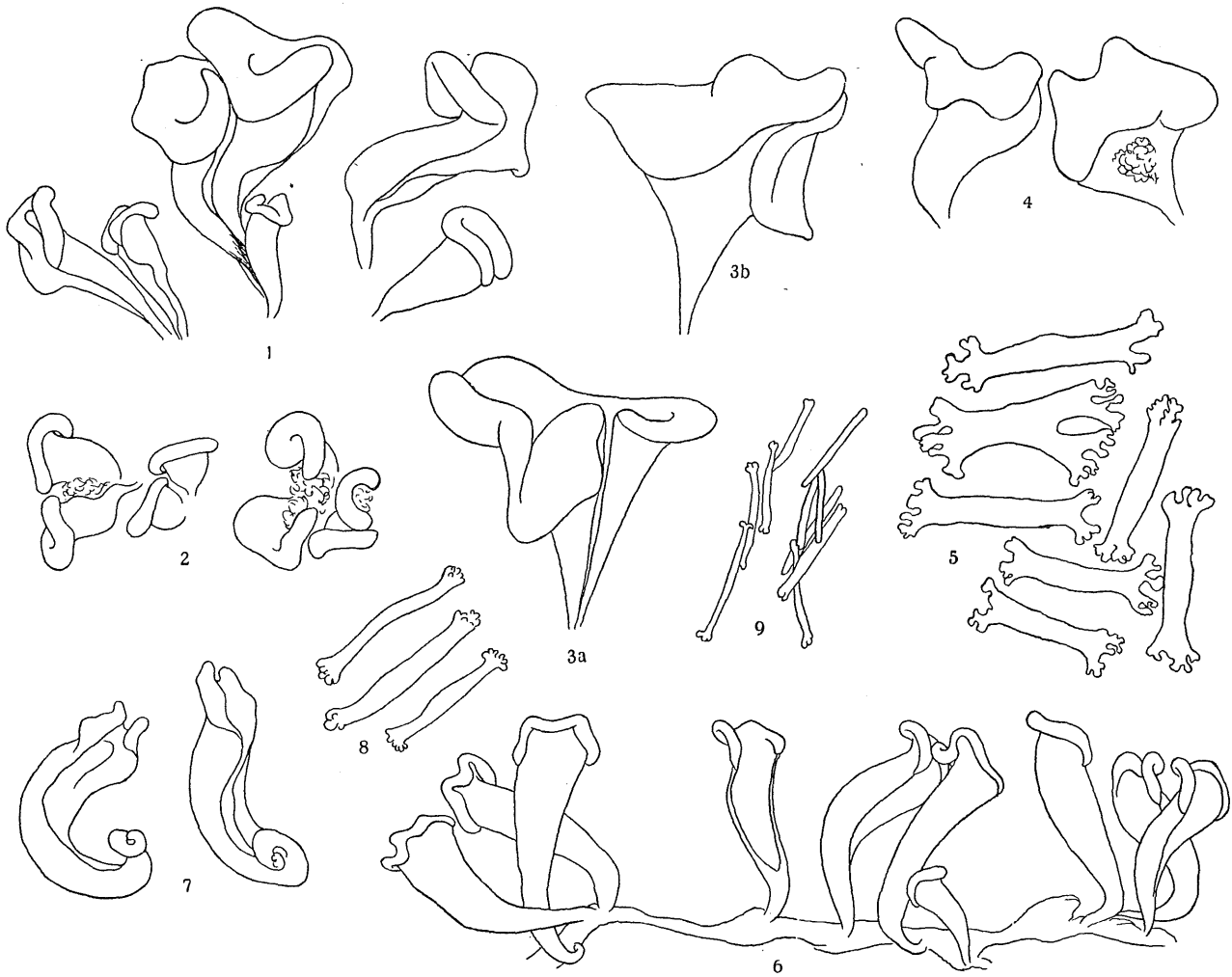

Fig. II. 1—5. *Chiridota pellucida*. 1—4 drawn after free funnels by means of a preparation microscope. 1. Ciliated funnel of a specimen from Seljasund, anterior end. 2. Ciliated funnels from the same specimen, posterior end. 3 a—b. A large ciliated funnel of a specimen from Berufjord. 4. Ciliated funnel of an old Norwegian specimen. 5. tentacle-rods. 6—9 *Chiridota spivourna*. 6. Ciliated funnels from the anterior end. 7. Ciliated funnels from the middle of the specimen. 8. Rods from tentacle-base. 9. Rods from a digit, drawn in situ.

from Berufjord there are only few funnels, but they are exceedingly large and open in the one side (Textfig. II, 3 a—b). The specimens from Norway 1866 has some few large funnels very like those from Berufjord (Textfig. II, 4) and the other specimens from Norway have funnels very like those from Seljasund, but they are not quite as large as the two largest ones.

The wheels are quite like those of *Ch. laevis*, and the tentacle-rods (Textfig. II, 5) are rather large and very branched.

There can be no doubt that *Ch. pellucida* is a valid species, distinctly different from *Ch. laevis*. The northern *laevis*-like species of *Chiridota* are much alike, and as the characters for separating them are very faint it seems reasonable to regard them as synonyms. The outer appearance of living specimens differ however so much that doubts as to the uniformity of the "circumpolar" *Ch. laevis* may easily arise. The examination of the large number of *Ch. laevis* at hand, has thrown light on the variation in the shape of the ciliated funnels, and thus it has been possible to use the shape of these organs for the classification, and with a rather high

degree of certainty. Naturally contracted or in other way less well-preserved specimens may be indeterminate when the ciliated funnels are the only characters used.

As is evident from the figures of *pellucida*-funnels from different localities, and from those of various forms of funnels from *laevis*, the funnels represent two distinctly different groups, so different that the specimens in which they occur cannot be supposed to be local variations of the same species. The same holds good of the two other *laevis*-like species, viz. *spirourna* and *groenlandica*.

Furthermore, there can be no doubt that the specimens described here as *pellucida* represent the same species as those described as *pellucida* by Sars in 1861. Sars' figures Pl. XV and XVI show that Sars not only has determined his Norwegian specimens as *pellucida*, but that he has clearly observed the differences between the ciliated funnels of this species and the funnels of the Greenland specimens of *laevis*.

That the specimens mentioned by Östergren in 1902 from Norway may be regarded as *pellucida* and not as *laevis* is evident from the fact that the Norwegian specimens described here have been determined by Östergren as *laevis*.

The conclusion hereof is that all the Norwegian *Chiridota*-specimens hitherto described as *laevis* are actually specimens of *pellucida*. *Chiridota pellucida* is for the present known to occur at the Norwegian coast from Bergen to Tromsø, and around the coast of Iceland in comparatively shallow water. Further records of *Ch. laevis* from North of Russia may be due to *pellucida* or perhaps *discolor* (Eschscholtz)¹.

Chiridota spirourna n. sp.

Pl. III, fig. 12.

Localities:

"Ingolf" St. 9 (64°18' Lat. N. 27°00' Long W.), 555 m. Bottomtemp. 5.8° — 1 frgm.

— St. 89 (64°45' Lat. N. 27°20' Long W.), 583 m. — 8.4° — 3 -

The fragments at hand represent a species which differ from *Ch. laevis* and *pellucida* in being much more hyaline, due to the exceedingly thin body-wall. There is only one fore-end (from St. 89). It has 12 tentacles with 4—6 pairs of digits, 10 large polian vesicles and a single stone-canal. The intestine has a large loop and on the mesenteries there are large ciliated funnels of a peculiar shape (Textfig. II, 6—7). There are only very few funnels in the specimens at hand. They are nicely preserved and one of the characteristics of the species is apparently the scarcity of funnels. In the anterior end of the body the funnels are rather like those of *pellucida*, but they are more slender and not so robust. Posteriorly in the specimens the funnels are more notched at the anterior end, and at the base they are nearly shaped like a french-horn (Textfig. II, 7). In the tentacles and digits there are numerous small rods with the ends more or less knobbed (Textfig. II, 8—9). They are different in both the size and the shape from the rods in *pellucida* and *laevis*. The wheels are found in a few large heaps on the dorsal side of the specimen. They quite agree with the wheels in *laevis* and *pellucida*.

There may be little doubt that *Ch. spirourna* is a valid species, which probably replaces *Ch. pellucida* in the deeper waters at Iceland.

¹) In a recent letter, T. Saweljew informs me that *discolor* must be regarded as closely related to *pellucida*, and perhaps as a variety of it.

Chiridota groenlandica n. sp.

"Rink" St. 155. about 400 m. Skovfjord, South Greenland $15/8$ 12 1 fragment

The fragment at hand is only 3.5 cm long, and lacks the anterior end. It was supposed to be a *Ch. laevis* from unusually deep water, but the peculiar ciliated funnels (Textfig. I, 16) evidently show that it cannot be a specimen of *laevis*. As the shape of the funnels is very characteristic and allows a recognition of the species, which is evidently unknown, it is considered most reasonable to name the species. Some fragments of a female gonad are found in the body-cavity.

Genus Achiridota Clark 1908.

Genotype: *Anapta inermis* Fisher.

Diagnosis (from Clark): Tentacles peltato-digitate, 12. Digits small and rather numerous (6—8 pairs). Body-wall without deposits. Polian vessel single, large. Calcareous ring well-developed.

Remarks: In the collection at hand there are two species which owing to the absence of calcareous deposits may be referred to Clark's genus. Only one species at hand, *Ach. profunda*, quite agrees with the diagnosis of the genus, the other, *ingolfia*, differs from it in having 11 polian vesicles, and a more "*Chiridota*"-like calcareous ring. The supposition lies at hand that this species is merely a *Chiridota* with the calcareous deposits dissolved. That this is not the case is evident from the presence of rods in the tentacles. The absence of deposits is ascertained by clarifying the whole specimen in xylol. Thus we have reasons for establishing a new genus of the *Chiridotidae*, but as only one specimen is present, I refer it for the present with a ? to the genus *Achiridota*¹⁾.

The other specimen, *profunda*, quite agrees with the diagnosis of the genus, and furthermore its peculiar calcareous ring quite agrees with that of *Achiridota inermis* (Fisher). This shape of the calcareous ring may no doubt be regarded as a generic character, which may perhaps be used for separating the two genera *Chiridota* and *Achiridota*. The calcareous ring and the large polian vesicle thus afford two valuable characters, as it may often be exceedingly difficult to ascertain whether calcareous deposits are actually lacking or not. This is especially the case when the absence of deposits in a specimen may be due to acid in the preserving liquid, in which case a specimen of *Chiridota* with dissolved deposits may be mistaken for an *Achiridota*.

It is very interesting to find a species of *Achiridota* in the North Atlantic, as the genotype originates from the Hawaiian seas. Both species are from comparatively deep water, the genotype from 466—772 m and *profunda* from 2700 m.

Achiridota profunda n. sp.

Pl. I, fig. 9.

St. 36 (61°50' Lat. N. 56°21' Long. W.) 2700 m, 1 specimen.

The single specimen at hand is about 30 mm long, and of a yellowish-brown colour, being faintly creamy with brown pigment scattered all over the body. It has 12 peltato-digitate tentacles, each with 14—16

¹⁾ Quite recently I have had the opportunity of ascertaining that this new species *Ach. ingolfi* may really be regarded as the genotype of a separate genus *Paradota* cfr. Heding: Die Holothurien der Deutschen Tiefsee-Expedition I, which is supposed to appear in the beginning of 1935.

digits (7—8 pairs). The calcareous ring is unusually thick (Pl. I, fig. 9), with no muscular impressions on its exterior side, as the tentacles are inserted in bowel-shaped incisions in the anterior side. The ring itself consists of 12 pieces, the five radial of which are perforated for the nerves. As there are no traces of a cartilaginous ring, the tentacle-canals are very distinct.

The alimentary canal consists of a conspicuous oesophagus and a voluminous intestine with a large loop. It is fastned to the body-wall in the usual way by three mesenteries, which are quite like the mesenteries found in most *Chiridota*. Ciliated funnels are not found, neither on the mesenteries nor on the body-wall, and as the specimen is rather well preserved, this indicates that the species totally lacks these organs, though more material is needed for stating this with certainty. The gonads are well developed and contain as far as may be seen both eggs and sperma. The gonads are rather long, unbranched, and consist of two different parts, as only the distal two thirds are glandular, the basal one being thin and translucent.

Calcareous deposits are lacking, both in the body-wall and in the tentacles. Whether this is due to the preserving liquid, or they are actually absent in living specimens, cannot be ascertained, but as the calcareous ring is well preserved, and there are no traces of deposits neither in the tentacles, nor in the body-wall, we may suppose that the absence of deposits is typical for the species. If not, we should be able to see from the calcareous ring that the specimen had been attacked by acid so as to totally dissolve the deposits. The presence of "wheel-heaps" can however nearly always be ascertained even when all the wheels have been dissolved.

The presence in the collection at hand of a species belonging to the genus *Achiridota*, is obviously quite perplexing. It is evident that the species described cannot be referred to *Chiridota*, as the peculiar calcareous ring, the large polian vesicle, and the absence of ciliated funnels distinctly separate it from this genus. On the other hand, the calcareous ring and the watervascular system so strikingly resemble the same organs in *Achiridota inermis* (Fisher) that it seems most reasonable to refer *profunda* to the same genus as *inermis*, i. e. *Achiridota*.

Even if future collections should show that *profunda* in spite of what is stated above, contains calcareous deposits, and thus cannot be regarded as a true *Achiridota*, there may be no doubt as to its specific value. The characteristic shape of the calcareous ring, the single polian vesicle and the unbranched gonads clearly separate it from all other Chiridotids known.

***Achiridota? ingolfi* n. sp.**

Pl. III, fig. 14.

St. 24 (63°06' Lat. N.—56°00' Long. W.), 2258 m. I specimen.

The specimen at hand measures about 30 mm in length, and is quite colourless in alcohol. It has 12 peltato-digitate tentacles, each with 6 digits (3 pairs). The calcareous ring is rather stout and consists of 12 pieces, the 5 radial of which are perforated for the passage of the nerves. The exterior side of the ring is supplied with very deep muscular impressions (Pl. III, fig. 14). There are 11 polian vesicles and one twined stone-canal with an irregularly folded madreporite. The alimentary canal consists of a short and narrow oesophagus, a voluminous glandular stomach and a thin-walled intestine with a large loop. It is fastned to the body-wall by the usual three mesenteries, which in their intestinal third only consist of fine threads. Ciliated funnels are only found on the anterior part of the dorsolateral mesentery. There are only few, not more than

10, and as they are unusually small, their shape is exceedingly difficult to make out. As far as may be ascertained, they are unstalked and consist of a short curved body and a large folded collar with a thick rim (Textfig. I, 17—18). The gonads are undeveloped and resemble small three-lobulate polian vesicles. Calcareous deposits are only found in the tentacles (Textfig. I, 19). As tentacle-rods, though rather small, are nicely preserved, the total absence of deposits in the body-wall is not due to dissolution, but must be regarded as a feature characteristic of this species. To ascertain with certainty that deposits are totally lacking in the body-wall, the whole specimen has been cleared in xylol and carefully examined.

The absence of calcareous deposits in the body-wall of this species clearly shows that it cannot be regarded as a *Chiridota*. According to Clark's characterisation of the genus *Achiridota*, the species *ingolfi* must be referred to this genus. However, the comparison of the specimen at hand with Fisher's description of *Anapta inermis*, the genotype of *Achiridota*, shows so marked differences that one may hardly think that the two species *ingolfi* and *inermis* are belonging to the same genus. For the present however, as we do not know more than a single specimen of *ingolfi*, it may be the most practical not to establish a new genus for it, wherefore I prefer to place it in the genus *Achiridota* with a¹⁾.

Family Myriotrochidae Östergren 1907.

Diagnosis: Synaptids of small or minute size. Number of tentacles 10—12. Calcareous ring composed of 10 pieces only, as the dorso-lateral interradials, when present, are united with the dorsal radials to a single piece supplied with 2 anterior projections. Polian vesicle and stone-canal single. Alimentary canal normally with a large loop. Gonads paired, branched or unbranched. Ciliated funnels absent.

Calcareous deposits of the body-wall more or less peculiar wheels, those of the tentacles, if present, either rods or wheels (cf. Ohshima 1915, pag. 287, Pl. II, fig. 36).

Remarks: There may be no doubt that this family differs so distinctly from the *Synaptidae* and the *Chiridotidae* that it is most reasonable to follow Östergren in separating it definitely from these both groups. The total absence of ciliated funnels and the shape of the calcareous ring may especially be regarded as characters of very high classificatory value. Also the shape of the wheels differs so distinctly from those found in the *Chiridotidae*, that they do not indicate any closer relation between these two families.

The family *Myriotrochidae* includes three different genera: *Myriotrochus* — *Acanthotrochus* — *Trochoderma*. These are so different, that it is hardly possible to state anything definite about their affinity to each other, but if we judge from the number of tentacles and the shape of the wheels, *Acanthotrochus* is more closely related to *Myriotrochus* than to *Trochoderma*, but as we do not know more than a single species of each of the two genera *Acanthotrochus* and *Trochoderma*, we should not for the present say too much about the inner classification of this family.

The shape of the calcareous ring in *Myriotrochus* and *Acanthotrochus* may be of some phylogenetic value. The coalescence of the dorso-lateral interradial and the dorsal radials point toward the *Molpadioidea* where the radials are always united with an interradial piece.

¹⁾ Cfr. the foot-note on pag. 16.

Genus *Myriotrochus* Steenstrup 1851.

Genotype: *Myriotrochus rinkii* Steenstrup.

Diagnosis: Small Synaptids with 10—12 peltato-digitate tentacles. Calcareous ring consists of 10 pieces, of which, in species with twelve tentacles, the two dorso-lateral ones are supplied with two anterior processes. Posterior processes absent. Polian vesicle and stone-canal single. Gonads paired. Alimentary canal with a large loop. Mesenteries often more or less reticulated, in *M. minutus* Östergren so reticulated that if not very closely examined, mesenteries seem to be lacking and replaced by some fine strands. Dorsal and ventral mesenteries are not coalesced.

Calcareous deposits of body-wall wheels with 10—20 spokes and 20—30 large teeth on the ring, those of tentacles, when present, either rods or spinuous ("*Trochoderma*"-like) wheels.

Remarks: As stated above, the genus *Myriotrochus* clearly differs from both *Acanthotrochus* and *Trochoderma*. The examination of the large material at hand, however, shows that Sars's genus *Oligotrochus* ought to be maintained, at any rate as a separate subgenus.

Myriotrochus rinkii Steenstrup.

Pl. I, fig. 4—7, Pl. II, fig. 1—4, 9—12, 23—25, 29—31.

Myriotrochus Rinkii Steenstrup 1851. En ny Form af de lungeløse og fodløse Søpølsers Gruppe, pag. 55,

Pl. III, fig. 7—10.

Chiridota brevis Huxley 1852. Journal of a voyage in Baffins Bay and Barrow-Strait etc. by Sutherland, Vol. II, Ap. pag. 221—22.

Myriotrochus rinkii Lütken 1857. Grønlands Echinodermata, pag. 22.

- — Théel 1877. Note sur quelques Holothuries des Mers de la Nouvelle Zemble, pag. 3, Pl. I.
- — Duncan & Sladen 1881. Mem. on the Echinodermata of the Arctic Sea to the West of Greenland, pag. 15, Pl. I, fig. 20—24.
- — Danielssen & Koren 1882. The Norwegian North-Atlantic Expedition, pag. 28, Tab. V.
- *brevis* part. Danielssen & Koren 1882. Op. cit., pag. 31.
- *rinkii* Levinsen 1886. Kara-Havets Echinodermata, pag. 387.
- — Ludwig 1900. Arktische und subarktische Holothurien. Fauna Arctica, pag. 160.
- — Östergren 1902. The Holothurioidea of Northern Norway, p. 14.
- — Michailovskij 1903. Zoologische Ergebnisse der Russ. Exp. nach Spitzbergen. Echinodermen.
- — Clark 1908. The Apodous Holothurians, p. 128.
- — Mortensen 1910. Report on the Echinoderms of North-East Greenland, pag. 227.
- — v. Hofsten 1915. Die Echinodermen des Eisfjords pag. 147—52.

Localities:

Norway (Bergen IX 1904 Fr. Johansen).

Kara Sea.

Nowaja Semlja.

Jan Mayen.

East Greenland (Tumignikitok — Tasiusak — Angmagsalik — Cape Dalton — Scoresbysound — Cape Stosch — Moskusoxefjord — Ødesund — Turner Sund — Forsblad Fjord — Mackenzie-Bay — Danmarks Havn — Heklas Havn).

West Greenland (Nanortalik — Skovfjord — Godthaab — Nordre Strømfjord — Godhavn — Umanak — Upernivik).

Labrador.

Though this species has been known for more than eighty years, it has not been satisfactorily described until now, and thus its relation to *Oligotrochus vitreus* Sars has not been clear. The exceedingly large material at hand, which for the greater part is nicely preserved, allows a rather complete examination and accordingly a rather complete description.

The size of the specimens at hand varies from 0.3 cm to at little more than 6 cm in length, and thus it very nearly reaches the largest size recorded (i. e. 6.5 cm). The colour in preserved specimens is highly varying, being pure white in some specimens, greyish and yellowish in others and dark black-brown in some few. From several of the localities the colour of living specimens is recorded, and in these cases it is stated to be faintly reddish, the body-wall glassy clear and quite translucent. There are normally twelve tentacles, all of equal size. In 1910 Mortensen mentions two specimens with but eleven tentacles. These have been carefully reexamined, and there may be no doubt that in both specimens the lacking tentacle is in regeneration, as there is a distinct interval for it, and furthermore the examination of the calcareous ring shows distinct muscles also for the lacking tentacles. Thus the lacking of the said tentacle cannot be regarded as a variation as did Mortensen. The tentacles are usually rather contracted, and accordingly their shape cannot in these cases be stated with certainty, but in a few specimens a single or two tentacles may be fully stretched out, and here it is seen that the tentacles are nearly hand-shaped (Pl. I, fig. 5) and supplied with about 10 digits of equal size. A terminal digit is lacking.

The calcareous ring is pure white and consists of 10 pieces of which the two dorso-lateral ones differ from the others in having two anterior processes. The radial pieces are perforated for the passage of the nerves, and the tentacle-muscles are fastened to the anterior and not to the exterior side of the pieces. As the shape of the calcareous ring in *Myriotrochus* and *Oligotrochus* is rather unique in the Synaptids, and as it is furthermore one of the best characters for separating the two species *M. rinkii* Stp. and *O. vitreus* Sars and thus for the present, also for separating the genera, it ought to be described more in detail. On Pl. II, fig. 1—4 is figured the left dorsal radial seen from the tentacles (2), the exterior (1), the interior (3) and from the side (4). As appears from these figures the two "anterior processes" are two large crests placed between the tentacle-inserations. The "processes", i. e. the crests seen from the exterior, appear to be of the same length as that of the calcareous ring proper. This is a somewhat varying feature, as the crests often may be somewhat higher, and in a few cases slightly lower. The crests are at any rate so large that the tentacles may be totally retracted between them, and in contracted specimens they can be seen as twelve small points round the oral disk. Pl. II, fig. 9—12 show the middorsal interrarial seen from four sides, quite as the dorsal radial. It appears that the anterior "process" is more slender and that the crest is more regularly shaped. From Pl. II, fig. 29—31 it is seen that the midventral radial in spite of small differences is very like the middorsal interrarial. In

Pl. II, fig. 17—19 are figured the three ventral pieces of the calcareous ring, and by comparison with the corresponding pieces of *O. vitreus* Sars it is evident that the calcareous ring is an easily used character for separating these two forms.

The ring canal is voluminous (Pl. I, fig. 7) and the very large polian vesicle is situated at the left ventral radial. The stone-canal is short and supplied with an exceedingly large madreporite. The shape of the madreporite may be very varying and the calcification of it may be so enormous that it totally coalesces with the middorsal interradiar. In Pl. I fig. 6, are shown two pieces of the calcareous ring of a specimen from "Danmark's Havn (East Greenland). The pieces are traced with hypochlorite of sodium, and in spite of this the madreporite is solidly united with them, and they are both united by the madreporite.

The gonads form two tufts placed in the anterior end of the specimens. The size of the gonoduct is rather varying. It is always very distinct, but in some specimens it is quite as wide as the three dorsal pieces of the calcareous ring. The gonoporus is a rather short transverse slit close to the tentacles.

The alimentary canal is usually rather thin and has a large loop. It is fastened to the body-wall by two mesenteries, a dorsal and a ventrolateral. The dorsal mesentery goes in the middorsal interradius until close to the posterior end of the specimen. Here it bends anteriorward, and turns towards the left dorsal longitudinal muscle. For a rather considerable length it is fastened to the lateral side of this muscle, and then it is fastened to the body-wall. This mesentery ends at about one third of the length of the specimen from the anterior end of the body and thus the anterior loop of the intestine is not fastened to the body-wall. The second mesentery is in its whole length fastened to the midventral longitudinal muscles, and not to the right ventral interambulacrum.

The wheels are often exceedingly numerous. They are by far the densest on the dorsal side of the specimen, and here again densest in the posterior end. They measure usually 110 μ to 250 μ in diameter and the number of spokes and teeth vary from 17 to 21 and 23—31, measurements and numbers which however vary within different specimens and localities. In the type-specimen from North-West Greenland the wheels measure 140—170 μ in diameter, the number of spokes is 17—21 and that of teeth 26—30, and the number of spokes 60—80 per cent. of that of the teeth. In the specimens from Labrador the wheels are 130 μ —210 μ in diameter, the number of spokes 16—22 and that of the teeth 19—24. The number of spokes is thus from 72 per cent. to 105 per cent. of that of the teeth as a few wheels has 20 spokes and only 19 teeth. In specimens from the Kara-Sea the wheels measure 170 μ —250 μ and the number of spokes is 19—20 and that of teeth 21—29. The number of spokes is here 65—90 per cent. of that of the teeth.

The wheels are often varying in a different way, and in the specimens from Labrador (and in some from East-Greenland too) the teeth may be supplied with two points (Textfig. III, 6). Théel's figure (sur quelques holothuries etc. Pl. I, fig. 5) is not quite correct, as the teeth and the spokes are very seldom arranged as shown in that figure (cf. Textfig. III, 1).

Myriotrochus rinkii Steenstrup is an easily recognisable species, which differs distinctly not only from the other arctic species of the genus and subgenus, but also from the different Pacific species described by Ohshima and Clark. According to the variation in the shape of the wheels and in that of the calcareous ring one is inclined to suppose that *M. rinkii* as described here include more different forms. In spite of the

rather large material at hand, and a careful examination of all the specimens, I have not succeeded in finding any clear characters by which it is possible to separate the supposed forms in varieties or species, and I am convinced that this is impossible even by further investigations of better material. Probably, such examinations may result in establishing some local races, but that these should be regarded as being of any higher classificatory value, as varieties or subspecies, cannot be expected.

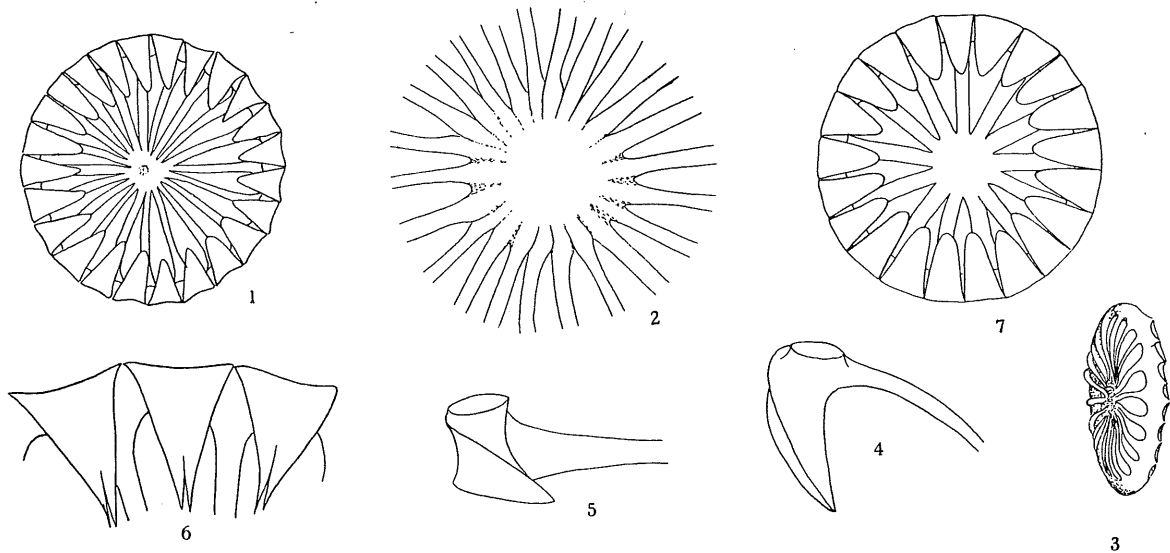

Fig. III. 1—6. *Myriotrochus rinkii*. 1. A normal wheel. 2. Centre of a normal wheel, showing the arrangement of the spokes, and the absence of knobs for the fastening of a strand. 3. A wheel seen partly laterally, showing the shape of the spokes. 4—5 show the arrangement of teeth, rim and spokes. 6. Three bifid teeth of a specimen from Labrador. 7. *Myriotrochus (Oligotrochus) vitreus* a normal wheel.

M. rinkii Stp. is a widely distributed species, which occurs all around in the arctic seas. It is interesting to see that while *Chiridota laevis* Fabr. does not occur at the east-coast of Greenland, this species is rather common on both sides of Greenland. At Norway *rinkii* is found as far south as Bergen.

In some of the specimens from Greenland some parasitic snails resembling *Entocolax* are found. These specimens are closer examined for seeing how far the presence of such parasites (up to seven in one specimen) has altered the morphology of the host, but such has not been found.

Subgenus *Oligotrochus* Sars 1866.

Genotype: *Oligotrochus vitreus* Sars.

Diagnosis: Moderate sized Synaptids with 12 tentacles. Tentacles not peltatodigitate as they have only 3—5 small digits on each side (pinnate?). Calcareous ring composed of 10 pieces, the two dorsal radials of which are double. Ventral pieces always with distinct posterior processes. Polian vesicle and stone-canal single. Gonads paired. Alimentary canal with a large loop. Mesenteries very distinct and distinctly coalesced at the anterior loop of the intestine.

Calcareous deposits almost lacking, as rarely more than 8—10 small wheels on the dorsal side are found, usually very posteriorly.

Remarks: The genus *Oligotrochus* was established by Sars in 1866 for his new species *O. vitreus*, but as this was soon regarded as a synonym of *Myriotrochus rinkii* Steenstrup, Sars's genus was abandoned as a matter of course. The examination of the collections at hand has, however, shown that Östergren is right in separating the two species dealt with, and further that there are better characters for separating them, than those shown by Östergren in 1902. These characters, the shape of the tentacles, that of the calcareous ring and the arrangement of the mesenteries are furthermore so different from the corresponding ones of *rinkii* that they do not allow a reference of the two species to the same genus. The shape of the wheels, however, shows that *Oligotrochus* is more closely related to *Myriotrochus* than to *Trochoderma* and *Acanthotrochus*, wherefore it will be most reasonable, at least for the present, to regard *Oligotrochus* as a subgenus of *Myriotrochus*.

Myriotrochus (Oligotrochus) vitreus Sars.

Pl. I, fig. 1—3, Pl. II, fig. 5—8, 13—22, 26—28, Pl. III, fig. 1—2.

Oligotrochus vitreus Sars 1866. Om arktiske Dyreformer i Christianiafjord, pag. 200.

Myriotrochus brevis part. Danielsen & Koren 1882. Norwegian North Atl. Exp., pag. 31.

Chiridota laevis C. G. Johs. Petersen 1898. Biol. Stations Beretning.

Myriotrochus vitreus Östergren 1902. The Holothurioidea of Northern Norway, pag. 19.

— — Clark 1908. The Apodous Holothurians, pag. 128.

— — Heding 1931. Die Synaptiden des Zool. Mus. zu Hamburg, pag. 695.

Localities:

Trondhjemsfjorden (Rødberg), 200—300 m. Östergren ²⁰ / ₈ 96	1	sp.
— (off Tautra), 200 m. Th. Mortensen ³¹ / ₇ 11	1	-
Bergen (Mangerfjord), Th. Mortensen ⁹ / ₈ 23	3	-
Skagerrak, S. of Arendal, 700—700 m. "Gunhild" St. 6. ¹⁰ / ₆ 79	1	-
— at the Norwegian coast. C. G. Johs. Petersen ²⁸ / ₇ 97	8	-
— ca. 570 m. C. G. Johs. Petersen ²¹ / ₅ 97	3	-
"Thor" St. 3. (58°32' N. 4°18' E.) 280 m. ³⁰ / ₄ 03	1	-
— St. 213b. 22 miles W.b.S. of Väderøerne. ¹⁰ / ₃ 04	1	-
— St. 223. 36 miles N.W.b.N. of Højen, Skagen, 535 m. ¹⁷ / ₄ 04	5	-
— St. 285. 44 miles N.W.b.N. of Højen, Skagen, 660 m. ⁴ / ₁₀ 04	2	-
— St. 1074. 18 miles S. of Oksö. 480 m. ²⁸ / ₅ 04	1	-
— St. 1569. (57°48' N. 7°40' E.) 440—460 m. ²¹ / ₄ 11	10	-
— St. 1572. N.b.W. ¹ / ₂ W. of Hirtshals. ²⁶ / ₇ 11	2	-

The specimens at hand are not all in the same good condition, some being nicely preserved, others being "heads", only, and when comparing the collection with that of *M. rinkii* it is evident that Östergren is right in stating that this species is much more fragile than *rinkii*. The specimens are generally large, measuring up to 5 cm in length. The colour is in alcohol either white or faintly red.

The number of tentacles is 12, and that of the digits about 10. The tentacles (Pl. I, fig. 2) are very conspicuous, being rather stiff, and "pinnate", having the digits placed on the sides. The shape of the tentacles is thus very different from that of the tentacles of *M. rinkii*, and this difference is even in highly contracted

tentacles quite distinct. As figured by Théel (1877 Pl. I, fig. 1) the tentacles of *rinkii* may be retracted in their own base, like the tentacles in *Chiridota*, but in the present species this is not the case. The tentacles may be highly contracted, but they are not retracted in the same degree as in *rinkii* where they may be almost hidden between the processes of the calcareous ring.

The calcareous ring (Pl. II, figs. 5—8, 13—22, 26—28) consists of 10 pieces the two dorsolateral of which are supplied with two anterior processes. The ventral pieces (Pl. II, fig. 17—22) have some large posterior processes, which as the bifurcate processes in the Molpadids serve for fastening of the water-vascular system. The calcareous ring is in almost all the specimens at hand clearly green, only a few less well preserved specimens have an almost quite white ring.

The oesophagus (Pl. I, fig. 3) is voluminous and thus it differs from that of *rinkii* which is rather narrow (Pl. I, fig. 7). The polian vesicle is large, and the stone-canal is short. The madreporite (Pl. III, fig. 1—2) is a very large irregularly shaped body. The gonads are paired and branched and the gonoduct opens with a rather large papilla close to the dorsal tentacles. The intestine has a large loop and especially the second descending part of it is very voluminous. The mesenteries are fused at the anterior loop of the intestine (Pl. I, fig. 1), and the second descending one is fastened to the middle of the mid ventral longitudinal muscle.

The wheels (Textfig. III, 7) are scarce, and are found usually in the posterior end of the dorsal side of the specimens. They measure 60—90 μ in diameter and have 12—14 spokes and 20—22 teeth on the ring. Östergren found a larger variation as he states (1902, pag. 19) that the number of spokes is 11—16 and the number of teeth (17) 19—26.

As stated above there is no doubt that *vitreus* is a valid species which can easily be separated from the species known of *Myriotrochus*, and especially from *rinkii*, with which it has previously been confounded. As is seen from the description, several of the characters by which it may be separated from *rinkii* are so important that it will be reasonable to place it in its own subgenus.

Genus *Acanthotrochus* Danielssen & Koren 1879.

Genotype: *Acanthotrochus mirabilis* Danielssen & Koren.

Diagnosis: Small Synaptids, with 12 tentacles. Digits 4—5, calcareous ring with only 10 pieces, as the two dorsolateral interradials are united with the corresponding dorsal radials.

Calcareous deposits wheels of two sorts 1) large ones resembling a steer-wheel, measuring about 250 μ and supplied with about 9 spokes and 2) small ones measuring 90—210 μ and with the same number of spokes, but with teeth on the rim as on the wheels of *Myriotrochus*.

Remarks: There is no doubt that *Acanthotrochus* must be regarded as a valid genus of the *Myriotrochidae*, to which family it must be referred owing to the shape of the calcareous ring and the absence of ciliated funnels. It is for the present a monotypic genus and the single species belonging to it has hitherto only been recorded by Danielssen & Koren.

Acanthotrochus mirabilis Dan. & Koren.

Pl. III, fig. 3—10.

Danielssen & Koren 1879. Echinodermer fra "Norske Nordhavs Expedition", pag. 115.

— 1882. The Holothurioidea, pag. 35. Pl. VI, fig. 8—20.

Localities:

St. 102 (66°23' Lat. N.—10°26' Long. W.), 1412 m.....	2	fragments.
St. 103 (66°23' Lat. N.—8°52' Long. W.), 1090 m.....	2	—
St. 105 (65°34' Lat. N.—7°31' Long. W.), 1434 m.....	1	—

Since Danielssen & Koren in 1882 described *Acanthotrochus mirabilis*, this species has not been found again until now, and as the type-specimens have never been reexamined, we do not know anything of this interesting species beyond the original description. Thus it is of considerable interest that the Ingolf collection includes some few, unfortunately rather poorly preserved specimens of *Acanthotrochus mirabilis* Dan. & Koren.

Only the fragments from St. 103 are in a condition to allow a closer examination. As far as can be judged from the size and general appearance, both fragments belong to the same specimen, which has been only little more than 10 mm long, the fragments measure about 4 mm and about 6 mm in length. There are 12 exceedingly retracted tentacles, each with four digits. Danielssen & Koren do not state anything about the number of digits, but their figure of a tentacle (Pl. VI, fig. 19) shows a large terminal digit and two pairs of lateral ones, and from the explanation of the figure it appears that they have only regarded the two digits on each side as a single large one deeply cleft. A careful examination of the present specimen by means of the binocular microscope as well as the examination of a preparation in Canada Balsam, do not show any terminal digit, and in balsam the distal part of a tentacle looks as the drawing (Pl. III, fig. 9) showing only two pairs of lateral digits.

Corresponding to the number of tentacles, the calcareous ring consists of twelve pieces (Pl. III, fig. 5—8), the two dorsolateral interradials of which are united with the dorsal radials. All the pieces have a large process on their anterior margin, and only those of the two dorsolateral interradials are slightly smaller than the others. The processes of the radials are somewhat wider than those of the interradials, and they are all five perforated for the nerves. The exterior surface of the processes, especially that

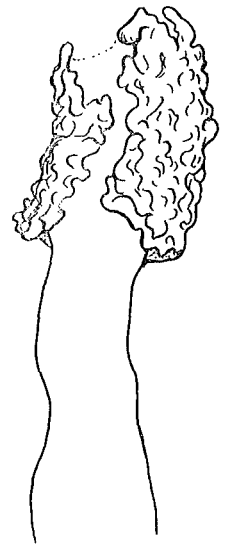

Fig. IV. *Acanthotrochus mirabilis*, stone canal and madreporite.

of the radial ones, is slightly excavated, and the posterior margin of all the pieces of the ring (also that of the two dorsolateral interradials) is supplied with a lunate incision. Thus, the calcareous ring of the specimen at hand in some degree differs from Danielssen & Koren's description, but as this is rather obscure the differences can not be regarded as having any systematic value, and only one, the presence of "minute protuberances" between the lunate incisions in Danielssen & Koren's specimens should be mentioned. Such protuberances do not occur in the specimen at hand, and from Danielssen & Koren's figure it appears that the incision between the "protuberances" most likely is a fracture between two pieces of the ring, and the protuberances themselves nothing but some irregularities in the edges of the slit.

There is one polian vesicle, placed a little to the left of the median line, as also stated by Danielssen & Koren, and one stone-canal. The madreporite is rather large and enclose a helm-shaped plate of calcareous network, with an irregular slit in its exterior side and a rather large opening at the top (Textfig. IV). Danielssen & Koren state that the madreporite (their "pyriform sack") includes calcareous reticulations, and figure

these reticulations in fig. 18, Pl. VI. In the figure at hand (Pl. III, fig. 3) is shown a bit of the calcareous network from the madreporite, and when comparing these two figures it can hardly be believed that they represent the same organ. The differences may, however, be ascribed to a beginning dissolution of the deposits in Danielssen & Koren's specimens. The calcareous network of the madreporite at hand shows in some parts a very peculiar appearance (Pl. III, fig. 4) which most likely is due to a beginning attack of acid in the preserving liquid as also the wheels in the body-wall of the specimen show faint, but pronounced traces of a beginning dissolution, which has occasioned the very interesting appearance of the deposit shown in Pl. III, fig. 10.

The gonads in the specimen at hand are well developed, and include eggs of different developmental stages. Whether they include sperma too, is impossible to ascertain owing to the preservation of the specimen.

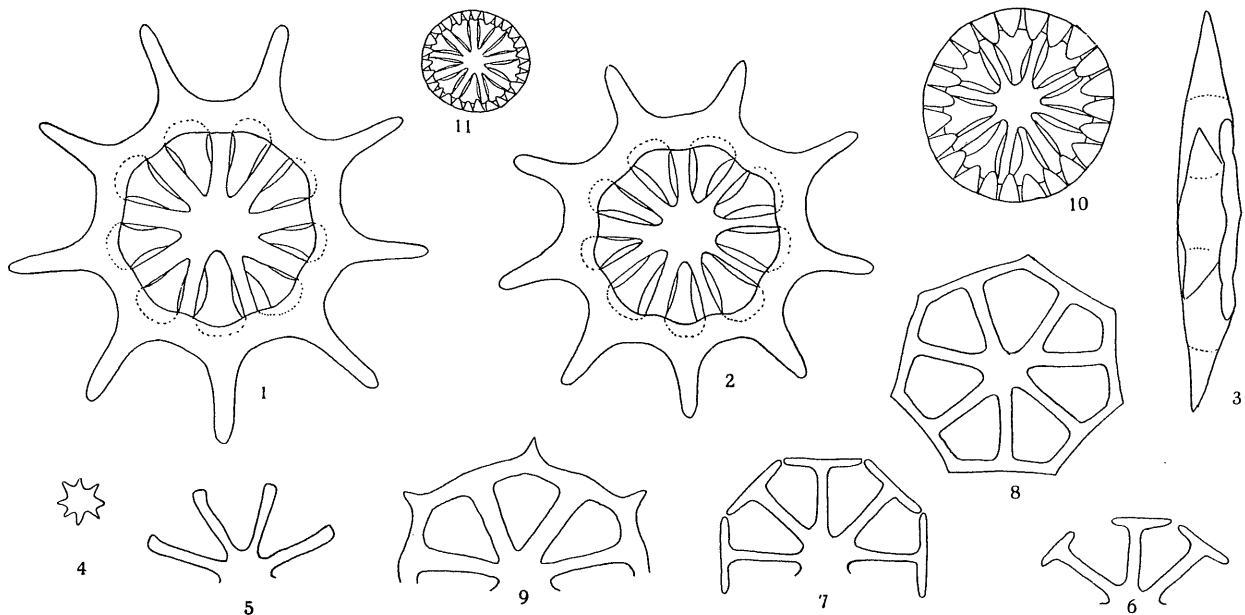

Fig. V. *Acanthotrochus mirabilis*. 1—3. Normal large wheels. 4—9. Different stages of development of large wheel. 10—11. Small wheels of different size.

The gonads consist in the right side of a rather large unbranched sack, but in the left side there are two such sacks of equal size.

As to the intestine, the mesenteries and "ciliated funnels", if any, the specimens at hand are too badly preserved for giving any information about these organs.

The large wheels (Textfig. V, 1—8 & Pl. III, fig. 10) agree rather well with the figure by Danielssen & Koren, but the centre of the wheels is never so regularly shaped as in that figure, and the spokes are always fastened distinctly to the underside of the rim, which is regularly but faintly undulated along the inner edge. The number of spokes may vary from 6 to 11, but usually there are 8—9. The size of the wheels is about 235μ — 260μ , thus being within the limits stated by Danielssen & Koren (220μ — 290μ). The wheels are often more or less abnormal with fewer spines than spokes, and some few may have the rim incompletely developed.

The small wheels differ rather distinctly from those in Danielssen & Koren's specimens, being much larger, 90 μ —210 μ (Danielssen & Koren state only 71 μ —98 μ), in having constantly 8—9 spokes (Danielssen & Koren, 11 spokes), and in having about 3 teeth per spoke (Danielssen & Koren, 2 teeth per spoke). Furthermore there are no traces of the wheels being stalked, and the central part is quite flat without any "round knob" (Textfig. V, 11).

The specimens at hand thus agree rather nicely with Danielssen & Koren's specimens, and only two marked differences, i. e. those of the tentacles and the small wheels, are found. Though, as the different statements of the tentacles may be due to the preservation of the specimens, and those of the wheels to specific variation, perhaps also to a less accurate examination of the type-specimens, there can be no doubt as to the specific identity of the specimens at hand and those described by Danielssen & Koren.

As *Acanthotrochus mirabilis* Dan. & Kor. has been found only twice, though in six different localities, we do not know much of the distribution of this species. No doubt it occurs everywhere in the depths between Iceland, Jan Mayen and Spitsbergen.

Genus *Trochoderma* Théel 1877.

Genotype: *Trochoderma elegans* Théel.

Diagnosis: Very small Synaptids with 10 tentacles. A single polian vesicle and no ciliated funnels. Gonads paired and branched.

Deposits exclusively rather large spiny wheels, which in uncontracted specimens almost fill out the skin, and in faintly contracted specimens are lying in so many layers as to make the body-wall quite firm.

Trochoderma elegans Théel 1877.

Pl. III, fig. 15—18.

Localities:

Nowaja Semlja, Matotskin Schar. 180 m.....	5 specim.
Kara Sea, Dijnphna Expedition.....	12 —
— (79°55' Lat. N. 88°58' Lat. E.) 185 m.....	1 —

The specimens at hand are all rather well preserved, though some of them are exceedingly contracted, even so contracted that the exterior layer of the body-wall forms a solid test, and the muscular layer is drawn from it, and lies firmly contracted in the interior.

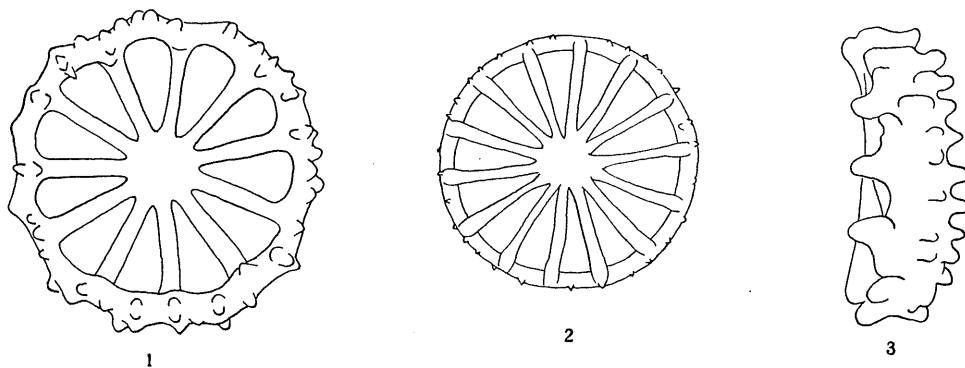

Fig. VI. Wheels of *Trochoderma elegans*.

There are 10 tentacles, a single polian vesicle and one stone-canal. The calcareous ring consists of 10 pieces, of which the radial ones are perforated for the passage of the nerves. The intestine has a large loop, and the longitudinal muscles are supplied with retractors which are very distinct, at any rate when the specimens are only slightly contracted. The gonads are paired, and in the specimens at hand all the male gonads are branched and the female unbranched.

The wheels (Textfig. VI, 1—3) may be more irregularly dented than figured by Théel, and there are usually two sorts of wheels in a specimen, a) the large robust ones (1 & 3) and b) the more elegant ones with small teeth (2).

Trochoderma elegans is an easily recognized species. It occurs in the middle deep arctic water usually on mud.

Quite recently, after this paper had been delivered to the press *Trochoderma elegans* has been mentioned by Thorson (Contributions to the Animal Ecology of the Scoresby Sound Fjord Complex (East Greenland) pag. 41 & 51.). The named author has taken it in different localities in Scoresby Sound, where it occurs as plentifully as 16—26 specimens pr. \square m, in depths of 65—325 m.

II. Molpadioidea.

The collection of North-Atlantic Molpadids in the Zoological Museum of Copenhagen like that of Synaptids, dates from different expeditions and for a lesser part also from private collectors. The material from some of these collections, e. g. that from the Amdrup Expedition to East-Greenland and the "Dijmphna" Expedition to the Kara Sea, has previously been described, by Lütken (1857), Levinsen (1887) and Mortensen (1903 & 1910). The rest is undescribed until now.

A careful examination of this rather large, and for the greater part nicely preserved collection, has led to interesting results especially concerning the anatomy and classification of this group.

As to the anatomy it is of special interest that I have been able to confirm the statements of Danielssen & Koren to the effect that the stone-canal in *Trochostoma* and *Ankyroderma* reaches the body-wall and that the madreporite is placed at the side of the stone-canal. Furthermore the specimens at hand have shown that not only is the stone-canal fastened to the body-wall, but it is opening in the exterior side of it with a distinct pore, which is often so large that it may be seen with the unaided eye, and it is possible to put a hair into it (cfr. Pl. VII, fig. 4). The part of the stone-canal which is placed between the madreporite and the body-wall, is in accordance with the embryological literature named the pore-canal.

Danielssen & Koren's statement concerning the stone-canal is mentioned by Clark in 1908 but is doubted according to Gerould's studies on the anatomy of *Caudina arenata* Gould. A long stone-canal with a side-standing madreporite and a distinct pore-canal which opens in the body-wall posterior to the genital porus is found in the genera *Trochostoma*, *Ankyroderma*, *Molpadia*, *Eumolpadia*, and *Paratrochostoma*. In the genus *Euphyrgus* the stone-canal is shorter and the madreporite is as it seems terminal, and the pore-canal is nearly rudimentary and reaches the body-wall closely anteriorly to the genital porus. In the genus *Caudina* the stone-canal is short and has an end-standing madreporite, and here the pore-canal is quite absent. In the new genus of the *Gephyrothurioidea*, *Molpadiodemas*, a stone-canal is totally absent, at any rate in both the two large specimens at hand.

Another anatomical feature of special interest is the presence of a fine stone-canal like organ situated in the dorsal mesentery of the most species referred to the family *Molpadiidae* as well as in the species *Molpadiodemas acaudum* n. sp. (cfr. Pl. III, fig. 19 ax.). This organ takes its rise from the ring-canal, posteriorly to the stone-canal (which is always placed on the anterior side of the dorsal part of the ring canal) and ends in the basal part of the gonoduct just where the latter unites with the paired gonads. The actual function of this organ cannot be made out without a histological examination, but there seems to be good reason for regarding it as the rudiment of an axial organ.

As to the taxonomy, the examination of these many specimens has confirmed Danielssen & Koren's and Hérouard's opinion that the presence or absence of anchors and rosettes of racquet-shaped plates may be regarded as valid generic characters. In 1908 (The apod. Holoth., pag. 18) Clark states that such a character cannot be used in the classification, as he has seen that the racquet-shaped plates in adult or, as Deichmann says, senile specimens, are transformed into the red phosphatic bodies, a feature which is also observed by other authors. Such transformations are often seen, and adult (senile) specimens are often found, which are lacking calcareous deposits in the body-wall, or at any rate in the larger part of it, as calcareous deposits are always found close to the two ends of the body-wall. As in these cases not only the anchors and racquet-shaped plates have disappeared but also the tables, and in some Pacific species (new species which have not been described) numerous intermediate stages of tables which are being transformed into phosphatic bodies, are found, I quite agree with Hérouard in regarding the transformation of the racquet-shaped plates as pathological, thus being of no classificatory value.

Another character which may be regarded of high value for the classification of the Molpadids, is the shape of the calcareous ring. This character has previously often been used in describing new species, but Mortensen (1925, pag. 363—67) was the first to use it as the systematical main character for separating the different species of *Caudina* (= *Paracaudina* Heding) from the Pacific. These species were united by Clark in 1908 under the name of *Caudina chilensis* Johs. Müller. The systematic value of the shape of the calcareous ring was recently doubted by Ohshima (The *Caudina* of Asamushi, 1929, pag. 42). In this paper he states as follow: "Mortensen tries to take the shape of the calcareous ring as one of the characteristics to distinguish holothurian species. So marked a structure, and so diversely formed, this organ is apt to lead one to regard it with too much importance in taxanomy. My impression is that the form and structure of the calcareous ring do show characteristics of each species, but are not in accordance with natural affinity of groups, being rather a variable due to adaption to the modes of life." This statement is not easily understood, as in 1925 Mortensen really used the different characteristics of the calcareous ring of each of the three species dealt with, as systematic characteristics, in the way allowed by Ohshima, but not for separating higher groups¹).

Contrary to Ohshima's opinion is that of the present author, who has found, in spite of the often rather large specific variation of the calcareous ring, that the shape of this organ is in the strongest correlation with the systematic place of the specimen. A correlation which is not alone specific but also generic, and even the two families *Molpadiidae* and *Caudinidae* may be separated by the mere appearance of the calcareous ring.

In using the above named characters, it is possible to separate families and genera within the *Molpadioidae*, as is done in my paper: "On the classification of the Molpadids", and the classification proposed in this "preliminary notice" is the same as adopted in the present work. By means of the said characters it is easy to separate Clark's genus *Molpadia* from his genus *Caudina*. There are of course no difficulties, when the specific characters of the North-Atlantic species are used, but as Clark did not give any real generic

¹) For a closer discussion of these problems see: Heding — The *Caudina* of Asamushi, the so-called *Caudina chilensis* (Johs. Müller). Sci. rep. Tohoku. Imp. University. 4 Ser. Biol. Vol. VIII No. 2 Sendai 1933.

characters, the two genera were in 1914 by Sluiter supposed to be synonyms (Die von Dr. v. Kampen gesammelten Holothurien, pag. 25).

As not only the North-Atlantic, but all the other species of the genus *Caudina* Clark examined by me have a short stone-canal with a terminal madreporite and no pore-canal, and all the species of *Molpadia* Clark, examined have a distinct pore-canal, the two groups of Molpadids are in this way easily separated (the preparation may be rather easy, even at contracted and badly preserved specimens). In using the shape of the calcareous ring in connection with that of the calcareous deposits, the two groups *Trochostoma* Hérouard and *Ankyroderma* (= *Molpadia*) Hérouard may also be separated without any difficulty. The presence or absence of anchor-rosettes may, as stated by Hérouard, usually be ascertained by examination of the specimens with rather slight magnification, or even with the naked eye. When anchor-rosettes seem to be absent, the shape of the calcareous ring nearly always will show with certainty, whether the specimen is an *Ankyroderma* or not. Just as the shape of the calcareous ring and the deposits afford characters usable for separating Hérouard's two groups from each other, the same characters allow the division of each of them into at least two. The characters most easily used for the division of these two groups, is the presence or absence of large fusiform or three-armed plates. The two genera with large fusiform plates in the body-wall, *Molpadia* and *Eumolpadia*, are mainly constituted of the species which Clark and Deichmann have united under the name of *Molpadia musculus* [or *holothurioides*].

In the present material there are only two specimens belonging to the genus *Molpadia* (subgenus *Paramolpadia*) and the genus *Eumolpadia* respectively. Though they differ distinctly from each other as well as from the other species at hand, they could not afford sufficient reason for establishing two separate genera, if I had not been able to examine a specimen of *violacea* Studer [Théel], one of Ludwigs specimens of "*Ankyroderma*" *danielsseni*, one of *spinosum* and Baldelli's two specimens of *musculus* Risso, as well as two specimens of a new species from South-Africa. The examination of these specimens as well as a careful consultation of the literature has shown it reasonable to establish the two different genera *Molpadia* and *Eumolpadia* for the species hitherto mainly referred to *Molpadia musculus* Risso as synonyms.

Beside the five genera mentioned, the "Ingolf" collections include some specimens, which in some characters are rather like the genus *Trochostoma* but in other characters are so different from all the species of the *Molpadiidae* that for the present they cannot reasonably be included in this family, but may provisionally be placed in the family *Eupyrgidae* Semper representing a separate genus and a new species i. e. *Paratrochostoma spinifer* n. g., n. sp.

At last it should be mentioned that the "Ingolf" Expedition has obtained two very large molpadid-like specimens from more than 3000 m depth. They are nicely preserved and differ in both eidonomy and anatomy distinctly from all other Holothurians. Most reasonably they are closely related to the two genera *Gephyrothuria* Koehler & Vaney and *Himasthlephora* Clark, and thus it will be better course to place them in the *Gephyrothurioidea* as a separate genus *Molpadiodemus* Heding.

As seen above the North-Atlantic Molpadids and allied forms may be separated into the following genera, which ought to be separated into the two orders *Molpadioidea* and *Gephyrothurioidea*.

Ordo I. *Molpadioidea*.

1. *Eupyrgus* Lütken.
2. *Paratrochostoma* Heding.
3. *Molpadia* Cuvier.
4. *Eumolpadia* Heding.
5. *Ankyroderma* Danielssen & Koren.
6. *Trochostoma* Danielssen & Koren.
7. *Haplodactyla* Grube.
8. *Caudina* Stimpson.

Ordo II. *Gephyrothurioidea*.

8. *Molpadiodemas* Heding.
- ?9. *Himasthlephora* Clark.
10. *Gephyrothuria* Koehler & Vaney.

These genera may be rather easily separated by means of the following key:

1. Longitudinal muscles paired, tentacular ampullae present..... 2.
Longitudinal muscles unpaired, tentacular ampullae absent..... 7.
2. Stone-canal short, not supplied with a distinct pore-canal which perforates the body-wall ... *Caudina*.¹⁾
Stone-canal long, pore-canal distinct and perforating the body-wall closely posterior to the gonoporus..... 3.
3. Anchors and rosettes of racquet-shaped plates present, calcareous ring deeply sculptured on the exterior side..... 4.
Anchors and rosettes of racquet-shaped plates absent, calcareous ring only faintly sculptured..... 6.
4. Fusiform and large perforate plates present in the body-wall..... 5.
Fusiform and large perforate plates absent in the body-wall, fusiform bodies present in caudal appendage..... *Ankyroderma*.
5. Muscular processes of radials either perforated or notched for the passage of the radial nerves *Molpadia*.
Muscular processes of radials with no passage for the radial nerves..... Subgenus: *Paramolpadia*.
6. Fusiform or in other way formed large bodies present in body-wall, muscular processes of radials perforated for the radial nerves..... *Eumolpadia*.
Fusiform bodies absent in body-wall, usually present in caudal appendage..... *Trochostoma*.
7. Calcareous deposits present in body-wall, caudal appendage present..... 8.
Calcareous deposits in body-wall as well as a caudal appendage, absent..... 9.
8. Large posterior processes on the radials, pore-canal distinct, calcareous tables "*Trochostoma*"-like (Textfig. XXI)..... *Paratrochostoma*.
Posterior processes on the radials either totally absent, or very rudimentary..... *Eupyrgus*.
9. Large whiplash-like appendices present on the dorsal side of body..... 10.
No whiplash-like appendices on dorsal side of body..... *Molpadiodemas*.

¹⁾ Owing to incomplete knowledge of the anatomy of *Haplodactyla*, this genus is in the key united with *Caudina*.

10. Besides whiplash-like appendices, small pedicel-like ones present *Himasthlephora*.
 Besides whiplash-like appendices and genital-papilla no other appendices on body-wall. *Gephyrothuria*.

Of these genera the present collections from the North Atlantic include the following 13 species:

1. *Eupyrgus scaber* Lütken.
2. *Paratrochostoma spiniferum* n. sp.
3. *Molpadia* [*Paramolpadia*] *diploa* n. sp.
4. *Eumolpadia asaphes* n. sp.
5. *Ankyroderma jeffreysii* Danielssen & Koren.
6. — affine Danielssen & Koren.
7. — — forma *groenlandica* (Mortensen).
8. *Trochostoma thomsonii* Danielssen & Koren.
9. — arcticum (v. Marenzeller).
10. — boreale (Sars).
11. *Caudina arenata* (Gould).
12. *Haplodactyla albicans* (Théel).
13. *Molpadiodemas acaudum* n. sp.

The following 7 species:

14. *Molpadia loricata* (Perrier).
15. — maroccana (Perrier).
16. *Ankyroderma agassizi* Théel.
17. *Trochostoma ooliticum* (Pourtalès).
18. — parvum Théel.
- ?19. — turgidum Verrill.
20. — blakei Théel,

which according to the older literature were to be expected from the area here dealt with, are lacking. These species are however all more southern, and though it may be supposed that species from the deep water of the Atlantic may have a rather wide distribution, the absence of these specimens in the material at hand, which includes all the northern species known, indicates that the Molpadids have a more limited distribution than previously supposed.

Order *Molpadioidea* Heding

Actinopoda Ludwig

Molpadonia Haeckel.

Diagnosis: Ape-date Holothurians, with posterior end of body usually tapering into a more or less pronounced caudal appendage (a caudal appendage is lacking in *Acaudina*). Tentacles except in *Ceraplectana* always 15. Exterior appendices of water-vascular system only present in shape of tentacles and anal papillae.

Calcareous ring composed of 10 pieces, the radial ones of which are normally supplied with two anterior processes and one large usually bifid posterior prolongation (this posterior prolongation may in the genus *Eupyrgus* be more or less reduced). Tentacle ampullae present except in the family *Eupyrgidae*. Pore-canal present except in the family *Caudinidae*. Intestine with a large loop and cloaca with two respiratory trees, of which the right one is always the larger.

Calcareous deposits perforated plates, tables, and anchors united with rosettes of racquet-shaped plates. According to Smith the anchors are optically built in an entirely different way than the anchors of the *Synaptidae*, with the optical axis in the prolongation of the anchor-stem. Deposits lacking in the tentacles.

Remarks: As shown above the order *Molpadioidea* ought to be separated from the order *Gephyrothurioidea*. If the two orders are actually more closely related, the *Molpadioidea* with the *Gephyrothurioidea* must be placed close to the *Synallactidae*, but any closer relation between the two orders here dealt with is not certain.

Family Molpadiidae Johs. Müller

(= *Trochostomidae* Östergren)

non *Molpadiidae* Östergren.

Diagnosis: Molpadids¹⁾ with tentacle-ampullae and a distinct pore-canal which opens with a single opening in the anterior end of the middorsal interambulacrum, close behind the gonoporus. Caudal appendage usually very short. Longitudinal muscles paired and without any retractors. Calcareous ring with distinct posterior processes on the radials. Muscular processes often perforated for the passage of the radial nerves. Respiratory trees and gonads paired.

Calcareous deposits tables, perforated plates, anchors, and rosettes of racquet-shaped plates, and fusiform bodies. Phosphatic deposits often present.

Remarks: As Östergren in 1907 divided the Order *Molpadioidea* into the three families *Molpadiidae*, *Trochostomidae* and *Eupyrgidae*, he used the name *Molpadiidae* for the family here called *Caudinidae*, as he followed Johs. Müller in naming my new genus *Paracaudina*, *Molpadia*. According to this he used the best known generic name i. e. *Trochostoma* for naming the family which included not only this genus, but also *Ankyroderma* and the real *Molpadia*. Without changing the division proposed by Östergren, it is thus considered most reasonable to change the names, in such a way, that the family *Molpadiidae* really includes the genus *Molpadia* and allied genera.

Of the family *Molpadiidae* four genera are represented in the collections at hand, i. e. *Paramolpadia*, *Eumolpadia*, *Ankyroderma* and *Trochostoma*. Of these the two first are only represented by one species each, the two others by two and three species.

Though the genus *Molpadia* is not represented in the collections at hand, it is supposed most reasonable to give a closer description of it. For this purpose the genotype was received from Italy, and thus it has been possible to draw the limits between the genera represented and the *Molpadia*, as well as between the genera mutually.

¹⁾ The term Molpadids is here used for all forms of the *Molpadioidea* as Synaptids may be used for all forms of *Apoda*.

Genus *Molpadia* Cuvier 1817.

Pl. V, fig. 13.

Molpadia Cuvier 1817. Règne animal Tome IV, pag. 23.

— Risso 1826. Historie naturelle de l'Europe méridionale Tome V, pag. 292.

— part. Selenka 1867. Beiträge zur Anatomie und Systematik der Holothurien, pag. 357.

— — Semper 1868. Die Holothurien, pag. 43.

Haplodactyla part. Théel 1886. Challenger Holothurioidea II, pag. 50.*Ankyroderma* Ludwig 1890. *Ankyroderma musculus* Risso, etc.

— part. Ludwig 1892. Die Seewalzen, pag. 355.

— — Perrier 1902. Expedition scient. du "Travailleur" et du "Talisman", Holothuries, pag. 528.

— — Koehler & Vaney 1905. "Investigator" Deep-Sea Holothurioidea, pag. 95.

Molpadia part. Clark 1908. The Apodous Holothurians, pag. 31 & 156.*Ankyroderma Baldelli* 1914. Asteroidi, ofiuroidi, crinoidi, olothuroidi raccolti nel mediterraneo dalla R. N. "Washington", pag. 104.*Molpadia* part. Clark 1920. Tropical Pacific Holothurioidea pag. 129.*Ankyroderma* (*Molpadia*) Hérouard 1923. Holothuries provenant des Campagnes des yachts "Princesse-Alice" et "Hirondelle II", pag. 130.*Molpadia* part. Mortensen 1927. Echinoderms of the British Isles, pag. 421.

— — Deichmann 1930 Westatlantic Holothurians, pag. 194.

Non.

Molpadia Johs. Müller 1850. Anatomische Studien über die Echinodermen.

— Hutton 1872. Catalogue Echinod. New Zealand.

— Théel 1886. Op. cit., pag. 55.

— Ludwig 1892. Die Seewalzen, pag. 355.

Genotype: *Molpadia musculus* Risso (= *Ankyroderma musculus* Baldelli).

Diagnosis: Molpadids of moderate size. Body oblong ovoid, in uncontracted specimens tapering into the rather short caudal appendage. Number of tentacles normally 15, that of digits according to Ludwig (1890, pag. 575) two, one on each side of the tentacle. Calcareous ring distinctly sculptured, so as to form rather deep canals for the tentacle-ampullae. Muscular processes of the radials hollowed for insertion of the longitudinal muscles, and perforated (often somewhat eccentrically) or notched for the passage of the nerves (the subgenus *Paremolpadia* has the radials neither perforated nor notched). Posterior processes of the radials rather long and of very nearly the same length. Polian vesicle single, rather large and usually stalked and placed at the left ventral radial process. Stone-canal long and thin and supplied with a rather large madreporite placed close to the body-wall, and with a distinct pore-canal which opens on the body-surface somewhat posterior to the gonoporus.

Calcareous deposits in the body-wall of three different sorts. 1) Anchors united with rosettes of racquet-shaped plates, 2) large fusiform or in other way formed perforated plates and 3) small tables with a perforated plate and a short and spiny spire. Small tables with an extra long spire may be found in some species e. g.

M. musculus (Ludwig 1890). In the caudal appendage there are numerous small fusiform bodies, usually supplied with a short spine.

Remarks: The genus *Molpadia* was established in 1817 by Cuvier (Règne animal I. IV, pag. 23), with the species *holothurioides* as the genotype. Neither the genus nor the species was however described in such a way that *Molpadia holothurioides* Cuvier is recognizable. Cuvier's description affords good reason for regarding *M. holothurioides* as belonging to the *Molpadiidae* in modern sense, but as for the present we know several distinctly different Molpadid-species from the eastern Atlantic, it is not possible to elect a single species as *holothurioides* Cuvier. Accordingly Clark in 1908 states that he is "unable to identify Cuvier's type-species (*holothurioides*) with any of the species known today", though, he has "very little doubt that the specimen was an example of *musculus* Risso". "As there is room for doubt" he continues, it "seems too unwise to attempt to replace the universally used name [*musculus* Risso] by the earlier one". In spite of this the same author in 1920 (Pacific *Holothurioidea*, pag. 129) replaces the name *musculus* Risso with *holothurioides* Cuvier, stating that "the acceptance of Cuvier's specific name is the most satisfying solution of the difficulty" [i. e. that we do not know the real genotype of the genus].

Clark's supposition that there is little doubt that Cuvier and Risso were dealing with the same species, seems quite inadmissible to me. There can be no doubt that Cuvier had a specimen from the Atlantic before him and Risso one from the Mediterranean. Certainly we have no reason for supposing that a Mediterranean species does not occur in the Atlantic, but as we know for the present two different species of Molpadids in the Mediterranean, *Molpadia musculus* Risso [Baldelli] and *Haplodactyla mediterranea* Grube [Baldelli], none of which are known with certainty to occur in the Atlantic (*mediterranea* (Baldelli) may possibly prove to be a synonym of *Haplodact. albicans* (Théel)), from where we know at least six different species which may be taken into consideration in the research for Cuvier's species, the possibility that Cuvier and Risso dealt with the same species is very slight. Therefore I do not hesitate in regarding *Molpadia holothurioides* Cuvier as a nomen nudum, which ought to be abandoned from modern literature, as also done by Hérouard in 1923, by Mortensen in 1927, and by Deichmann in 1930.

Concerning the generic name *Molpadia*, Cuvier's very insufficient description has occasioned much confusion. As to the older literature, this was collected and thoroughly discussed by Ludwig in 1890 (*Ankyroderma musculus*, pag. 569—574). In this paper Ludwig suggests that *M. holothurioides* Cuvier and *M. musculus* Risso are synonymous, but in spite of this, he refers the discussed species *musculus* to Danielssen & Koren's new genus *Ankyroderma*. This he also did in 1892 (Die Seewalzen, pag. 355) and in this book he furthermore follows Johs. Müller and Semper in using Cuvier's generic name *Molpadia* for the species *chilensis* Johs. Müller and *australis* Semper.

As Clark in 1908 wrote his monograph on the Molpadiidae, he referred the two species *chilensis* Johs. Müller and *australis* Semper as well as Hutton's *coriacea* to Stimpson's genus *Caudina*, and used the name *Molpadia* for that of his molpadid-groups which enclosed Risso's and Ludwig's species *musculus*. The genera *Ankyroderma* Dan. & Koren and *Trochostoma* Dan. & Koren were by Clark regarded as mere synonyms of *Molpadia*. In 1910 (Sur les molpadides de Norvège) Hérouard pointed out that there is much reason for maintaining the two genera *Ankyroderma* and *Trochostoma*, the former he thought to be synony-

mous with Cuvier's *Molpadia*. In 1923 (Holothuries, pag. 127—130) Hérouard further discussed this question and reached at the same conclusion, but his division of Clark's genus *Molpadia* into two genera was adopted neither by Mortensen (1927) nor by Deichmann (1930).

As stated above (pag. 30) the examination of the present collection as well as that of all the other Molpadids in the Zoological Museum of Copenhagen, has led to the division of Clark's genus *Molpadia* into more different ones. A closer discussion of some of these, i. e. *Haplodactyla* Grube, *Trochostoma* Dan. & Kor. and *Ankyroderma* Dan. & Koren is given below under the respective genera, and here the genus *Molpadia* Cuvier is only dealt with.

The real genotype, *Molpadia holothurioides* Cuvier is not known, and as stated above, we have no reasons for expecting that it may ever be found. As to the type-specimen of *M. holothurioides*, Ludwig states (*Ankyroderma musculus*, pag. 573) that it does not exist, and according to Ludwig the same is the case with the type of *musculus* Risso. When thus leaving Cuvier's species entirely out of consideration, we are not alone allowed to, but also obliged to elect a new genotype for the genus *Molpadia*. The most reasonable then, will be to take *Molpadia musculus* Risso as the genotype of *Molpadia*, but this species also involves great difficulties. Risso certainly did not describe his species in such a way as to make the identification quite certain. When Ludwig in 1890 described the specimens from Naples, he had no doubt that they represented Risso's species, as this was the only molpadid he knew from the Mediterranean (Grube's *mediterranea* he regarded as synonymous with Risso's species). I have no doubt that Ludwig is right in this, but as we know various species from the Mediterranean we cannot be quite certain. In preparing the present paper I have tried to obtain Ludwig's specimens for a reexamination, but also these specimens seem to have disappeared. Thus it will be most reasonable to elect Baldelli's specimens of *Ankyroderma musculus* (cfr. *Asteroidi* etc., pag. 104—105) as the neotype of *Molpadia musculus* Risso which species must then be regarded as the genotype of *Molpadia*.

The genus *Molpadia* Cuvier is not represented in the collection at hand. The only species (*diploa*) which may be referred to it differs (as well as a species from South Africa, *capensis*) so much from the genotype that it is most reasonable to place them in a separate subgenus *Paramolpadia* Heding.

Subgenus *Paramolpadia* Heding 1931.

Genotype: *Paramolpadia diploa* n. sp.

Diagnosis: Molpadids of small or medium size. Body ovoid, in uncontracted specimens tapering into the well developed caudal appendage. Number of tentacles 15, that of digits unknown. Calcareous ring deeply sculptured on the exterior side, and with the ridges between the ampulla-canals expanded posteriorly into wing-like bodies. Muscular processes of radials neither perforated nor notched for the passage of the radial nerves. Posterior prolongations of radials of nearly the same length and usually bifid at the end. Polian vesicle single and placed at the left ventral radial-prolongation. Stone-canal long and supplied with a large madreporite close to the body-wall and a pore-canal, which opens on the body-surface, somewhat posterior to the gonoporus.

Calcareous deposits in body-wall 1) Anchors united with racquet-shaped plates, 2) large fusiform or

fenestrated plates and 3) small tables with perforated plate and spiny spire. In the caudal appendage there are numerous small fusiform bodies, usually with a short spire.

Remarks: The specimens referred to the subgenus *Paramolpadia* differ from the *Molpadia*-species mainly in the shape of the calcareous ring. Apparently it is unreasonable to establish a subgenus, but the differences are so striking, and probably also so important that I prefer to separate the two groups.

***Molpadia (Paramolpadia) diploa* n. sp.**

Pl. V, fig. 11, Pl. VII, fig. 1, Pl. VIII, fig. 8.

Locality: "Thor" St. 43 (43°37' N. 2°08' W.). 480—1500 m., 15/5 06. 1 specimen.

The specimen at hand measures 3.6 cm in length and 1.6 cm in diameter, and has an 1.6 cm long caudal appendage. The colour is of a rather dark reddish brown, and only the caudal appendage and the peristome are pale grey.

The skin looks and feels rough and spiny, and even to the naked eye the rosettes of racket-shaped bodies are distinct.

Owing to the contraction of the specimen, neither the number of tentacles nor that of digits can be ascertained directly, but the shape of the calcareous ring shows that the number of tentacles is 15. The calcareous ring (Pl. V, fig. 11) is very peculiar. The anterior projections (except the muscular ones of the radials) are shaped as large wing-like crests stretching posteriorly over the exterior side of the ring. Close to the posterior margin of the ring the crests or ridges divide into two wings, which cover over the ampulla-canal. The muscular projections of the radials are shorter and thicker than the others, and on the exterior side they are distinctly hollowed for the insertion of the longitudinal muscles. A perforation for the radial nerve does not exist (for being quite certain, the ring is treated with hypochlorite of sodium). The radial pieces have rather thin posterior prolongations, to which the ring-canal is fastened.

The ring-canal is supplied with a single large polian vesicle, placed at the left ventral radial-projection. The stone-canal is long and thin and reaches to the body-wall where it has a large madreporite and a distinct pore-canal which opens closely posterior to the gonoporus. An axial-organ? is present and is found in the basal part of the dorsal mesentery. It takes its rise from the circular canal posteriorly to the opening of the stone-canal and unites with the gonads where these unite with the gonoduct. The gonads are but faintly developed, paired and much branched, and the very long gonoduct opens close to the dorsal tentacles with a small transverse slit. The intestine has a large loop and a short but distinct cloaca. Owing to the contraction of the specimen the mesenteries cannot be followed exactly, but they are mainly fastened in the middorsal inter-radius, the left dorsal and the right ventral ones. The respiratory trees are well developed. The right one reaches to the calcareous ring to which it is fastened by solid strings, and the ventral one is only half as long.

There are different kinds of calcareous deposits. In the median part of the body-wall (Pl. VII, fig. 1) there are rosettes of racket-shaped plates normally united with an anchor, perforated plates, and small tables. The rosettes usually consist of six racket-shaped plates, in a few cases there are found five, four or seven. The racket-shaped plates are of almost the same size and shape, but a single or two of them are often smaller and more irregularly shaped, and rosettes, consisting of very rudimentary, bodies are found. The anchor-stem is composed of three rods and the arms are serrate, but owing to the rather rough handling of the

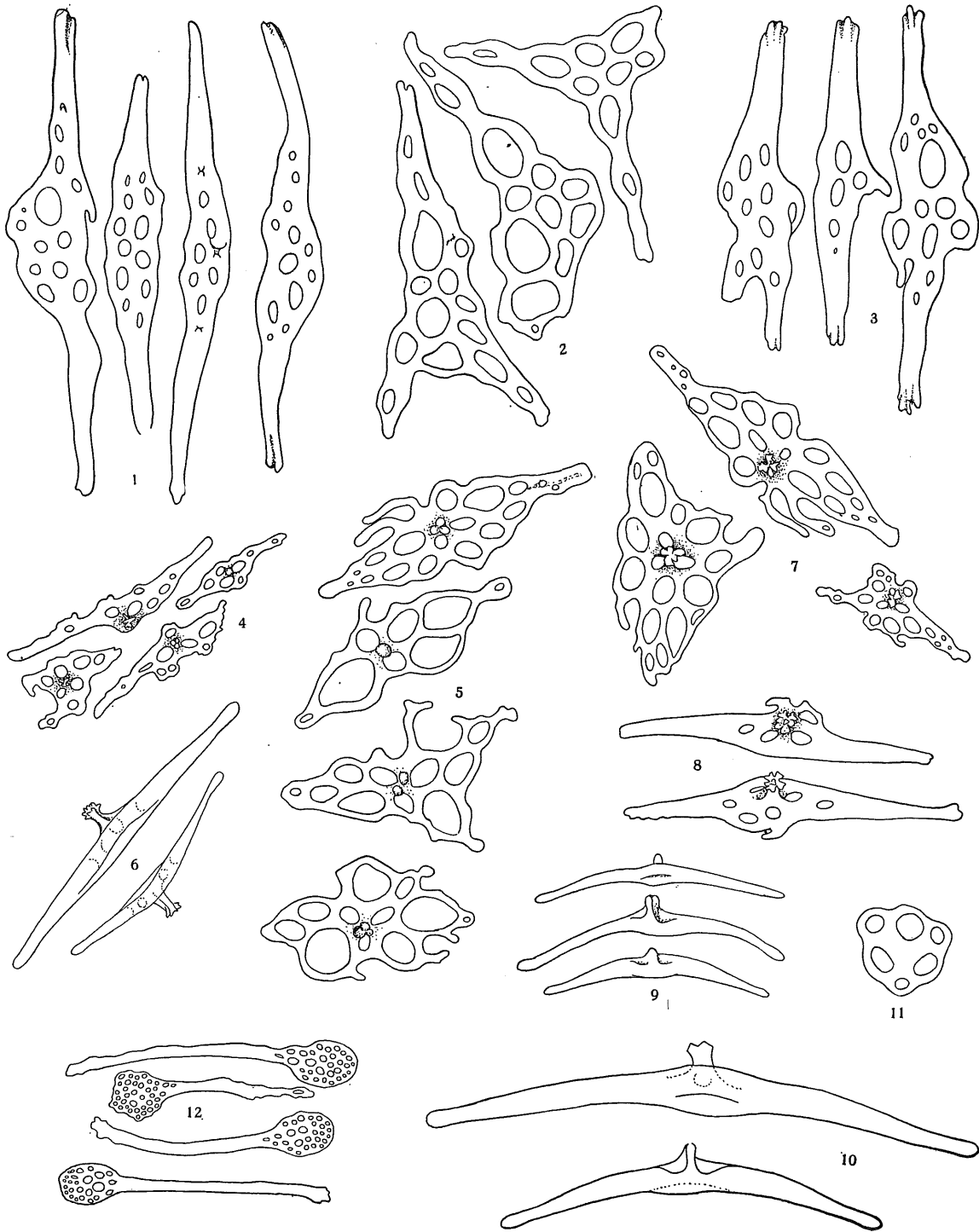

Fig. VII. *Molpadia (Paramolpadia) diploa*. 1—3. Perforated and fusiform plates. 1 from anterior end, 2 from middle, 3 from posterior end of specimen. 4—8. Tables. 4 from anterior end, 5—6 from the middle. 7—8 from the posterior end of the specimen. 9—10. Fusiform deposits from caudal appendage. 11. Base of an anchor-stem. 12. Racquet-shaped plates.

specimen when caught, complete anchors are not found. The base of the anchor-stem consists of a rounded triangular plate, perforated by three large and three small perforations, the larger of which being placed between the traces of the rods of the stem.

The perforated plates (Pl. VII, fig. 1 & Textfig. VII, 2) are about 1 mm large and often more or less conspicuously triangular deposits with 10—20 large holes. A spire is always absent. The shape of the perforated plates is much varying, but in spite of this their general appearance is rather characteristic, in com-

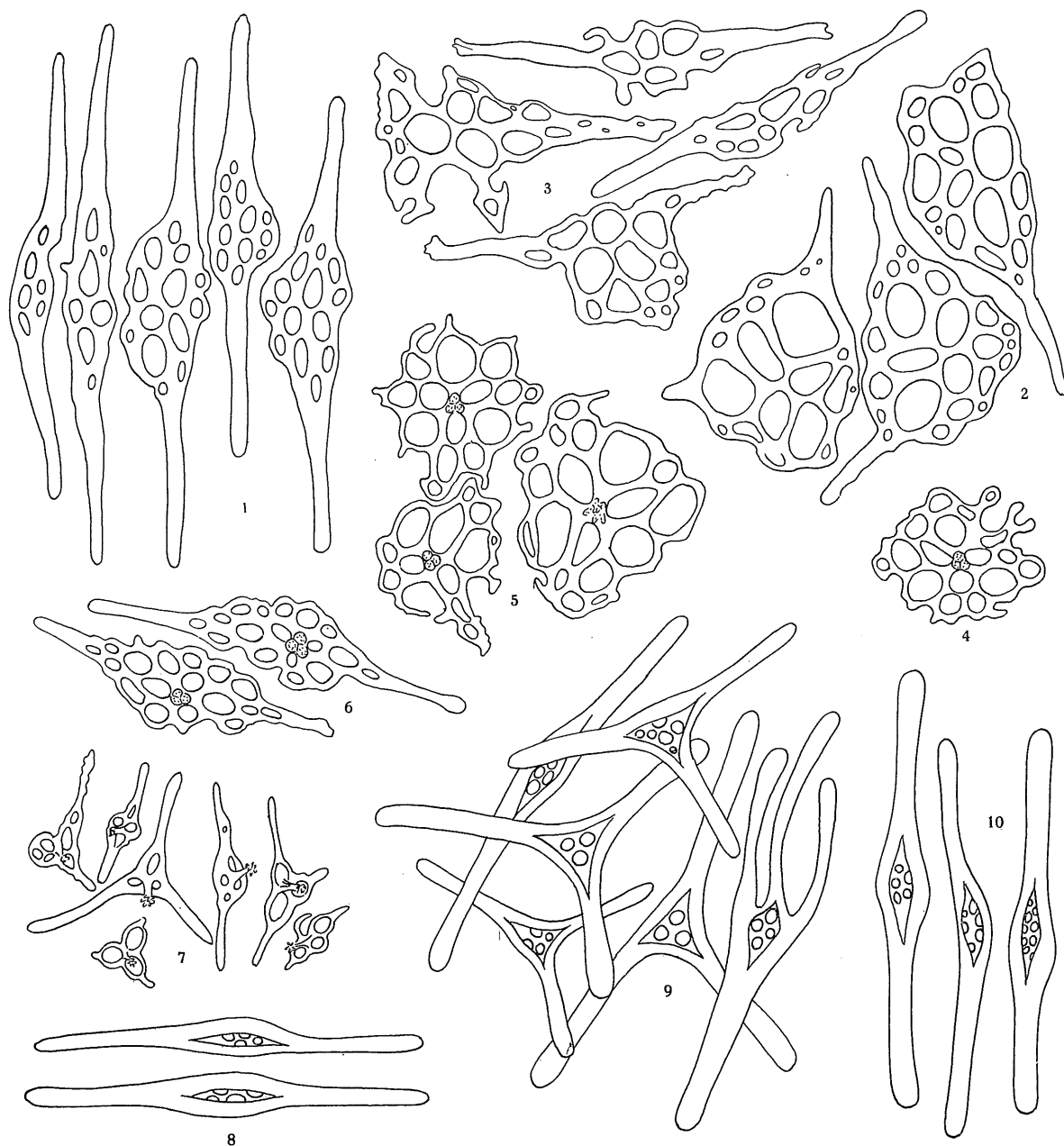

Fig. VIII. 1—6. *Molpadia (Paramolpadia) capensis*. 1—3. Perforated plates. 1 from anterior end, 2 from middle, 3 from posterior end. 4—6. Tables. 4 from posterior end, 5 from middle, 6 from anterior end. 7—10. *Eumolpadia violacea*. 7 tables, 8—10 fusiform bodies, 8 from anterior end, 9 from middle, 10 from posterior end.

parison with the specimens of the South-African species *capensis* n. sp. and of *Molpadia musculus* Risso [Baldelli] (Pl. VII, fig. 2 & Textfig. VIII, 2—3). The tables (Pl. VII, fig. 1 & Textfig. VII, 5) are very like the perforated plates, but they are a little smaller and not so robust, and always supplied with a short and spiny spire (Textfig. VII, 6).

In the most anterior as well as in the most posterior end of the body, anchors and rosettes are absent, but in both places there are perforated plates and tables. Both forms of deposits are fusiform in the anterior end of the body. The perforated plates (Textfig. VII, 1) are very long (about 1—1.5 mm) and supplied with rather many round holes of varying size. The perforated plates in the posterior end of the body (Textfig. VII, 3) are also fusiform, but they are not so long as those in the anterior end, and they may be faintly branched. The tables in the posterior end of the body (Textfig. VII, 7—8) are rather varying in shape and often nearly as large as the perforated plates. At either end of the specimen where the skin is contracted, it is easily seen that the perforated or fusiform plates and the tables are lying in different layers in the body-wall, the tables being always placed more exteriorly than the large perforated plates. This is also the case in the medial part of the body, but as the skin is here more distended, tables covering the perforated plates are only seldom found. The ratio between tables and perforated plates is about one to four.

In the caudal appendage there is a dense layer of small curved fusiform rods with a short spire (Textfig. VII, 9—10). These are largest and most faintly curved in the proximal part of the appendage, and become smaller and more curved toward the anus. As it has not been possible to examine the anal papillae more closely, the shape of the deposits in these cannot be stated.

Besides the calcareous deposits, the skin encloses numerous phosphatic bodies. These (Pl. VII, fig. 1) vary in size and are collected in small groups. It is nowhere seen that they attack the calcareous deposits, as may be seen in specimens of other species. The red bodies are absent in the caudal appendage in the most anterior end of the body and in the very small areas round the opening of the pore-canal and the gonoduct.

Molpadia (Paramolpadia) diploa is very closely related to the South-African species *M. (Param.) capensis* Heding¹⁾, but differs in the shape of the calcareous deposits so much from this form that they are doubtless separate species.

As to the distribution of this interesting species only little can be said, its only finding place being the station of the "Thor", but as it originates from depths of more than 500 m (up to 1500), it may be supposed to be distributed throughout large parts of the deep waters of the north-eastern Atlantic.

Genus *Eumolpadia* n. g.

Molpadia part. Clark 1908. The Apodous Holothurians, p. 156.

Haplodactyla Heding 1930. On the classification of the Molpadids.

Genotype: *Haplodactyla asaphes* Heding.

Diagnoses: Tentacles normally 15, number of digits unknown. Body oblong ovoid with a relatively long caudal appendage. Calcareous ring solid, radials with a large bifurcate posterior prolongation, and a large muscular process, which is distinctly perforated for the passage of the nerves. Polian vesicle single. Stone-canal long, reaching to the body-wall and supplied with a large lateral madreporite and a distinct pore-canal which opens posterior to the gonoporus. Gonads and respiratory trees paired.

¹⁾ A close description of this species cannot be given here, but in order to clearly showing the limits of *M. diploa*, it is necessary to give some figures of the calcareous deposits as well as of the calcareous ring of this more southern species. As the specimens of *capensis* at hand are dried up, it is only possible to make out that the species has tentacle-ampullae, a long stone-canal with a distinct pore-canal, and that the right respiratory tree is fastened to the calcareous ring.

Calcareous deposits tables with perforated disk and large fusiform or triangular rods. Anchors and rosettes of racquet-shaped bodies absent.

Remarks: In working out this report more than five years ago I was convinced that *Haplodactyla mediterranea* Grube was one of the synonyms of Clark's *Molpadia musculus*, and as this species proved to include two genera, I thought it natural to name one of them *Haplodactyla*. As however, I thereupon received Baldelli's *Trochostoma mediterranea* for reexamination I saw that the reasons for regarding this species identical with Grube's *Haplodactyla mediterranea* were very strong, but as Baldelli's species apparently was to be referred to the family *Caudinidae*, I preferred to maintain the name *Haplodactyla* for my new genus based on the species *asaphes* Hdg. In the years since then I have now and then dealt with Molpadids, and the result of my studies is that the two species *albicans* Théel and *mediterranea* Baldelli which were previously both referred first to *Trochostoma* and then to *Caudina* (*mediterranea* cf. Hedding 1931) could not be the same genus as *arenata*. Thus we have to establish a new genus for these two species and allied forms, and then it is most reasonable to regard Grube's and Baldelli's two species, which are both named *mediterranea*, as identical and then use Grube's old name *Haplodactyla* for the genus including this species.

The genus *Eumolpadia* includes for the present besides the genotype *asaphes* (Hdg.) only the two species *violacea* (Studer) and *intermedia* (Ludwig). It resembles the genera *Molpadia* and *Paramolpadia* in several characters, but differs distinctly from both in the shape of the calcareous ring and the total absence of anchors and rosettes of racquet-shaped plates. The classificatory value of these two organs is however denied by Clark and Deichmann.

As to the presence or absence of anchors and rosettes these authors state that this feature is due to the age of the specimens, as they have observed that anchors and rosettes are always lacking in old senile specimens. Certainly every investigator of Molpadids will find that in old specimens with a dense layer of phosphatic deposits, calcareous deposits are often totally or nearly totally lacking, but that this should be a reason for denying the classificatory value of these organs I cannot see. Then we could quite as well deny the classificatory value of the teeth of mammals, these are certainly often lacking in senile specimens.

The two above authors as well as Ohshima seem unable to realise the characteristic feature of the shape of the calcareous ring, what is highly regrettable. It is difficult, I admit, and one may easily be mistaken about the details, but nevertheless the calcareous ring is of a high classificatory value.

***Eumolpadia asaphes* n. sp.**

Pl. V, figs. 9—10, Pl. VII, fig. 2, Pl. VIII, fig. 3.

Locality: "Ingolf" St. 36 (61°50' Lat. N. 56°21' Long. W.), 2700 m. Bottomtemp. 1.5°, 1 specimen.

The specimen at hand measures 2.5 cm in length and 1.5 cm in diameter, and has a 0.6 cm long caudal appendage. The body-wall is in the anterior and the posterior end much contracted, but in the middle it is strongly distended. The colour is pale grey with small red spots. The skin is smooth both to the sight and to the touch, and thus it is distinctly different from that of *Molpadia diploa*, which species *asaphes* rather resembles in the general appearance.

Owing to the contraction of the specimen, neither the number of tentacles nor that of the digits can be ascertained, but the shape of the calcareous ring shows that the tentacular number is 15. The calcareous ring (Pl. V, fig. 9—10) is rather stout and consists of 10 pieces. It has on its anterior margin 10 large and thin crest-shaped projections and for the insertion of the longitudinal muscles 5 stout and solid ones. On the posterior margin of the radials there are rather long bifid projections. The muscular projections are in

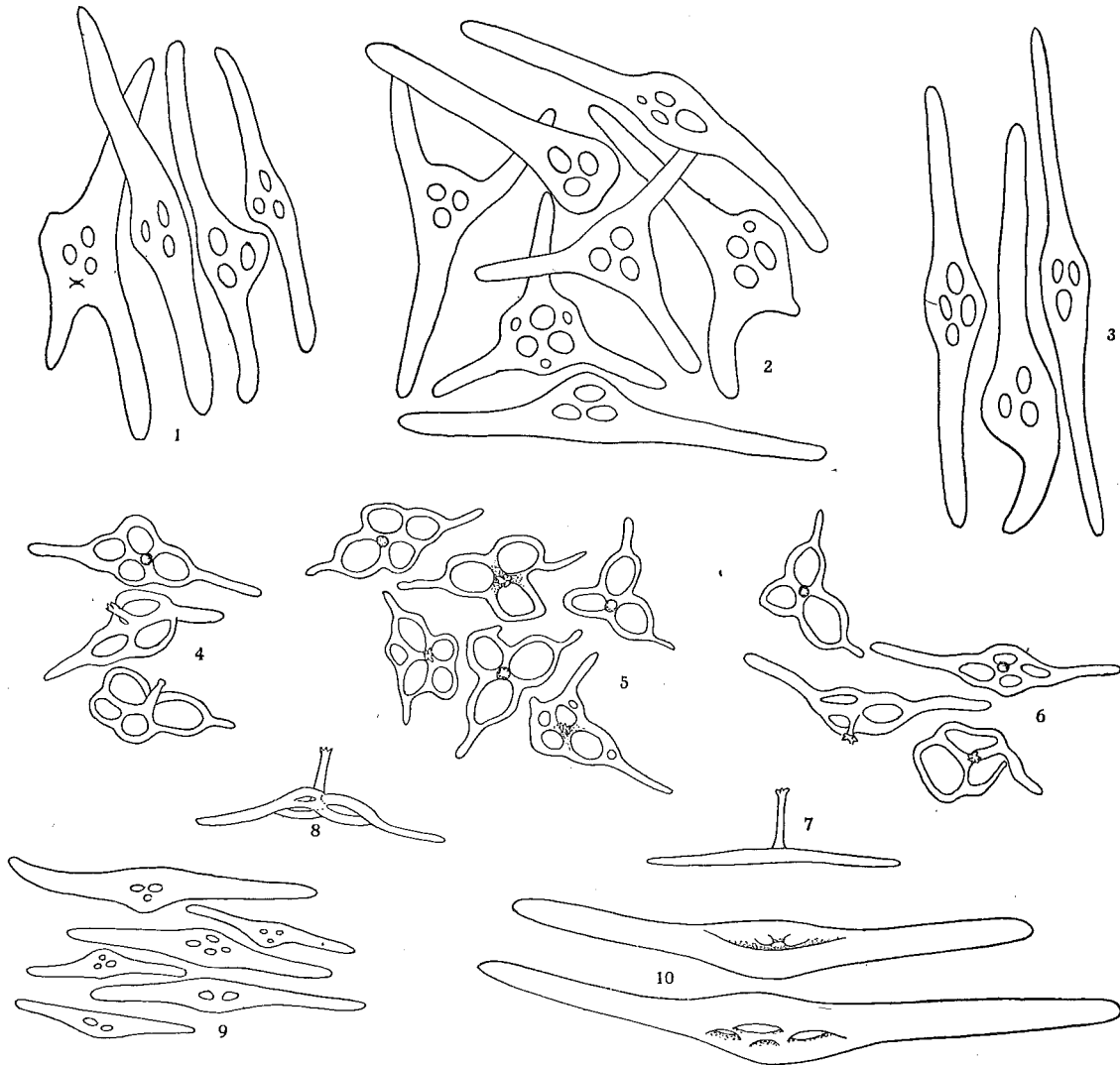

Fig. IX. *Eumolpadia asaphes*. 1—3. Fusiform bodies, 1 from posterior end, 2 from middle, 3 from anterior end. 4—8. Tables, 4 from posterior end, 5 from middle, 6 from anterior end. 7—8. Seen laterally. 9—10. Fusiform bodies from the caudal appendage.

their exterior side hollowed for the insertion of the muscles, and in the anterior part of this cavity there is a distinct perforation for the passage of the radial nerve.

The ring-canal is fastened to the ends of the bifid projections of the radials. There is a large polian vesicle at the left ventral radial process, and a long and thin stone-canal in the mid-dorsal interambulacrum. Directly posteriorly to the stone-canal there is an axial-like organ, which reaches from the ring-canal to the gonads where those from the two sides unite with the gonoduct. The stone-canal is fastened to the body-wall and supplied with a large madreporite and a distinct pore-canal, which opens on the body-wall a little

posteriorly to the gonoporus. The gonads are rather undeveloped, but paired and somewhat branched. The gonoduct is long and opens close behind the dorsal tentacles. The intestine has a large loop, and the right respiratory tree reaches to the calcareous ring to which it is fastened by strong strings. The left respiratory tree is only half as long as the right one.

The calcareous deposits of the body-wall are of two different sorts, 1) two- or three-armed "fusiform" bodies and 2) small tables with a rather long spire. In the median part of the body, the "fusiform" plates (Textfig. IX, 2) are either two- or three-armed. They are faintly hollowed in the middle where they have normally three round perforations. The number of perforations may often be four or six and in very few cases five or another number. In either end of the body real three-armed deposits are absent, but especially in the posterior end some of the plates may have a little third arm (Textfig. IX, 1). The tables are rather alike all over the body. They are usually four-holed and have a shorter or longer rod in each side (Textfig. IX, 4—6). The spire is rather long and slender, and is faintly spiny at the end (Textfig. IX, 7—8).

The rods in the caudal appendage (Textfig. IX, 9—10) are rather small and fusiform. They are of varying size and have the median part somewhat hollowed. A spire as that found on the caudal rods in *Molpadia diploa*, is absent.

Besides calcareous deposits, there are also phosphatic bodies in the skin. They are rather small and are found in small scattered groups between the calcareous deposits Pl. VII, fig. 2. Phosphatic bodies are absent in the caudal appendage and in the anteriormost part of the body. *Eumolpadia asaphes* is most closely related to *Eumolpadia violacea* (Studer) [Théel], which species it resembles in the shape of the calcareous ring and in the shape of the large three-armed plates. The two species differ however so much that there can be no difficulty in separating them. Like *Molpadia diploa* this species may be excepted to be widely distributed in the deep water of the Atlantic ocean.

Genus *Ankyroderma* Danielssen & Koren.

Genotype: *Ankyroderma jeffreysii* Danielssen & Koren.

Diagnosis: Large or moderate sized Molpadids. Body oblong ovoid with a short caudal appendage. Number of tentacles 15, that of digits three. Calcareous ring distinctly sculptured, so as to form rather deep canals for the tentacle-ampullae. Muscular processes of radials faintly hollowed for the insertion of the longitudinal muscles, but not perforated for the passage of the radial nerves. Posterior prolongations of calcareous ring long and very nearly of equal size. Polian vesicle single and placed opposite to the left ventral radial process. Stone-canal long and thin. Mad₁eporite large and side-standing. Pore-canal short and thick and opening dorsally closely posterior to the gonoporus.

Calcareous deposits in body-wall of two different sorts 1) Anchors united with rosettes of racquet-shaped plates and 2) small irregular usually three-holed or rod-shaped tables. In the caudal appendage there are numerous fusiform bodies supplied with a short spire.

Remarks: The genus *Ankyroderma* was established by Danielssen & Koren (Norwegian North-Atlantic Expedition, pag. 67) for the species with anchors and rosettes of racquet-shaped plates in the body-wall (i. e. *jeffreysii* and *affine*). In 1891 Ludwig referred Risso's species *Molpadia musculus* to Danielssen

& Koren's genus, and in 1908 Clark collected both *Ankyroderma* and *Trochostoma* in the single genus *Molpadia*. Already in 1910 Hérouard showed in a preliminary note (Sur les Molpadides de Norvège) that Danielssen & Koren's two genera could not reasonably be united into a single one, and in 1923 (Monaco Résultats 66) he definitely separates them, but owing to the presence of anchors in both *Molpadia* and *Ankyroderma*, he supposes these two genera to be identical and he replaces the name *Ankyroderma* by *Molpadia*. Later, in 1927 and 1931 neither Mortensen nor Deichmann follow Hérouard in separating the genera *Trochostoma* and *Ankyroderma* (*Molpadia*). As shown above there are reasons, not only for separating the genera *Trochostoma* and *Ankyroderma*, but for dividing Clark's genus *Molpadia* into 5—6 different genera.

The genus *Ankyroderma* is represented in the collections at hand by two species, *jeffreysi* Dan. & Kor. and *affine* Dan. & Kor. The two species are in fact very alike, but the differences in the shape of the calcareous deposits may be sufficient for clearly separating them.

***Ankyroderma jeffreysi* Danielssen & Koren.**

Pl. III, fig. 19, Pl. IV, figs. 7—8, Pl. V, fig. 14, Pl. VII, fig. 4, Pl. VIII, fig. 5.

Ankyroderma jeffreysi Danielssen & Koren 1879. Echinodermer fra den norske Nordhavs Expedition, p. 128,

Pl. V & VI.

— Danielssen & Koren 1882. The Norwegian North Atlantic Expedition, pag. 67,

Pl. X—XI—XII.

Molpadia oölitica Clark 1908. The Apodous Holothurians.

Ankyroderma jeffreysi Hérouard 1910. Sur les Molpadides de Norvège.

— Hérouard 1923. Holothuries provenant des campagnes des yachts etc., pag. 130, Pl. IX, fig. 11.

Localities:

"Thor" St. 51 66°02' N. 11°5' W., 1040—900 m.....	3	specimens
Flemming Inlet North-East Greenland	1	—
Vöringen St. 261 Nord Cap	1	—

The specimens at hand are all more or less dark red to quite purple, only the caudal appendage and the anterior end of the body are pale white and the tentacles are whitish yellow. On the dorsal side of the body both the gonoporus and the opening of the pore-canal are easily discernible when the specimens are examined by the unaided eye. They form small whitish spots of which the gonoporus is about three times as large as the other. The two pores are found rather closely together and the gonoporus is always placed anteriorly of the other. The tentacles are nearly all totally retracted, but a few may be examined. They are distinctly trilobate, having one digit on each side. The rosettes of racquet-shaped plates may usually be rather easily seen by means of a weak lens. They form small whitish stars arranged in irregular longitudinal rows in the interambulacra.

The calcareous ring (Pl. V, fig. 14) is very solid. It is distinctly "*Ankyroderma*-shaped" having very deep insertions for the tentacular muscles and especially for the tentacular ampullae. The muscular processes are short and wide and faintly hollowed for the insertion of the longitudinal muscles. They are not perforated for the passage of the radial nerves. The posterior prolongations of the radials are rather faint and so distinctly separated from the radial proper that they should be called processes. They are of different

length, the ventral ones always being the shorter. The dorsal and the lateral ones are pointing a little ventralwards.

The polian vesicle is single, and the stone-canal is as described by Danielssen & Koren very long and supplied with a large side-placed madreporite and a short and distinct pore-canal, which pierces the body-wall (Pl. VII, fig. 4). Like the madreporite the pore-canal is much calcified. The intestine has a large loop and a distinct cloaca. It is fastened to the body-wall by the usual three mesenteries, which are arranged in the usual interradii (Pl. VIII, fig. 5). In all the specimens at hand the gonads are well developed, and in-

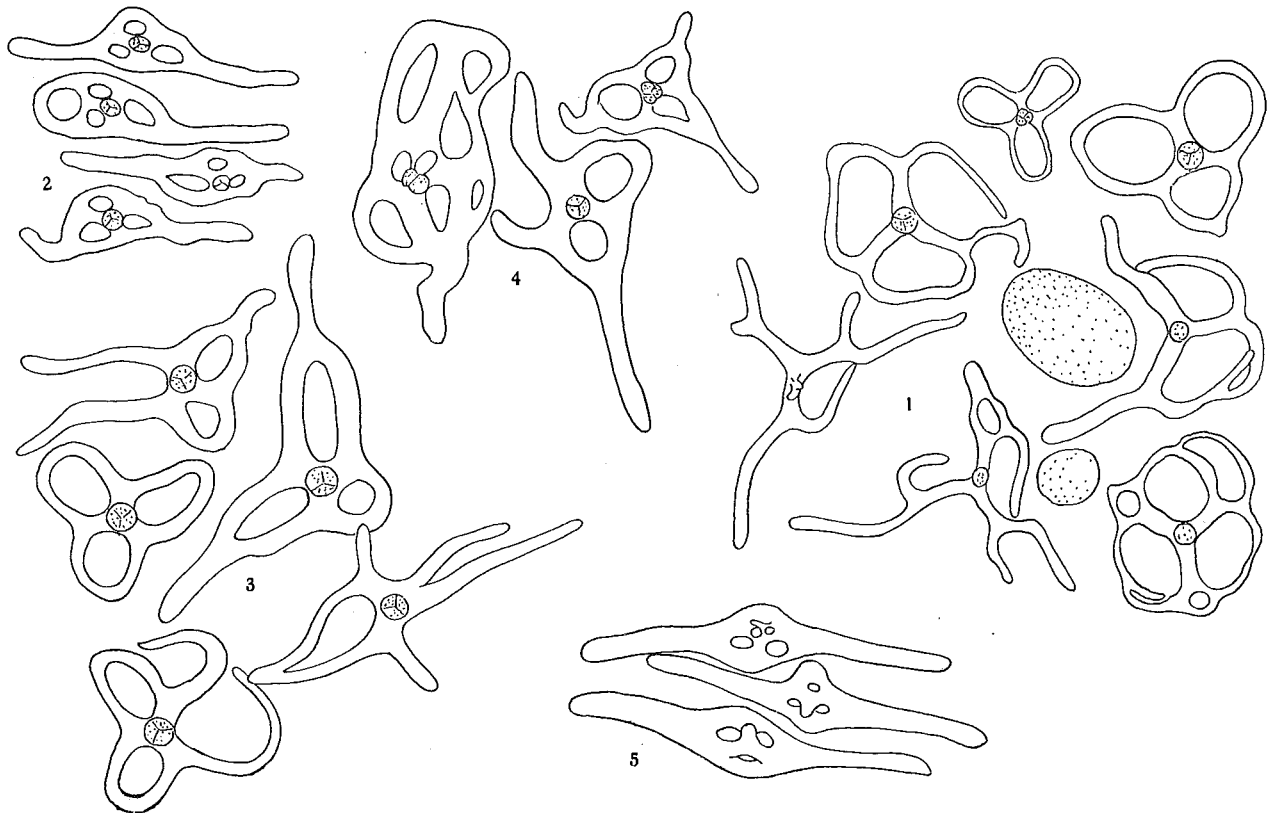

Fig. X. *Ankyroderma jeffreysii*. 1 from the middle of a cotype. 2—5 from a specimen from "Thor" St. 51. 2 from anterior end, 3 from middle, 4 from posterior end, 5 from caudal appendage.

clude few not fully developed eggs. The gonoduct is long and opens without any papilla closely posterior to the tentacles. In the original description Danielssen & Koren figured the gonoporus as a little wart (cf. Tab. X, fig. 13 d), but according to the cotypes (types?) at hand this is obviously wrong. The respiratory trees are well developed and especially the right one is bushy-branched. They are of different length, the right one being the longer, and reaching to the calcareous ring, where it has its end between the strands which unite the oesophagus with the calcareous ring. The longitudinal muscles are paired, and without any real retractor. The two side-halves unite close to the calcareous ring forming a retractor-like body, by which they are fastened to the muscular processes (Pl. III, fig. 19).

The calcareous deposits are much varying in the different specimens, and usually the great number of large and deeply red phosphatic bodies makes the examination of these very troublesome.

The anchors and rosettes are quite like those of *affine*. As stated above they are rather easily found in the interradial, but in large specimens they may be scarce in the middle of the body. The tables are much varying in shape, and are furthermore much different in the three parts of the body. No pronounced difference between the deposits on the dorsal and ventral side of the specimens as found in *Tr. thomsoni* is seen. The tables in the specimens from "Thor" St. 51 are very solid (Textfig. X, 3) and in the middle of the specimens often rodshaped. In the anterior end of the specimen the rods are small and less nicely developed. The same is the case with the rods round the gonoporus and the opening of the pore-canal (Textfig. X, 2). Here the phosphatic deposits are lacking, and the calcareous deposits are diminishing toward the pore. In the caudal appendage there are numerous fusiform rods (Textfig. X, 5). The tables in the specimens received from Bergen (the types or cotypes) are apparently of the same kind as those of the other specimens at hand, but they are more slender (Textfig. X, 5). It is interesting to see that in these specimens many of the tables are more or less attacked by the red phosphatic deposits, which may often quite enclose them, and then probably absorb them. This is a very important feature, as Clark, in 1908, states that the anchors and rosettes of racquet-shaped plates cannot be of much classificatory value, as they may be resorbed by means of the red bodies. No doubt both anchors and tables are of high classificatory value, but as apparently they may both be partly or totally replaced by phosphatic bodies in old and "senile" specimens, they are in such cases rather unusable, and then we are compelled to use the shape of the calcareous ring as the only feature usable for the determination of species, and as this shape may be exceedingly alike in the different species of the genus *Ankyroderma*, senile specimens will be almost indeterminable. As the number of red bodies may be varying in the specimens and may be highly increasing with the age of the specimens, these deposits cannot be regarded of much value to the classification.

In spite of what has been stated above, there is only little doubt that *Ankyroderma jeffreysi* is a valid species. In 1908 Clark suggests that *jeffreysi* is synonymous with *oëlitica* (Pourtales), but as shown by Deichmann in 1930 as well as by Hérouard in 1910 and 1923 these two species are so different that there is no reason for supposing them to be synonyms. Thus the large distribution of "*oëlitica*" cannot hold good of any of the two species referred to it, as *oëlitica* should be regarded as a West-Indian species, and *jeffreysi* as an arctic and more European species.

***Ankyroderma affine* Danielssen & Koren.**

Pl. IV, fig. 12, Pl. V, figs. 15—16, Pl. VIII, figs. 6—7.

Ankyroderma affine Danielssen & Koren 1872. The Norwegian North-Atlantic Expedition, pag. 71, Pl. XII, fig. 28—36.

Trochostoma boreale Mortensen 1903. Echinoderms from East Greenland, pag. 89.

Molpadia affinis Clark 1908. The apodous Holothurians, pag. 163.

?*Molpadia blakei* v. *groenlandica* Mortensen 1910. Report on the Echinoderms of North East Greenland, pag. 284.

Localities:

"Ingolf" St. 4 (64°07' N. 11°12' W.), 446 m. Bottomtemp. 2.5°	4 specimens
— St. 126 (67°19' N. 15°52' W.), 552 m. Bottomtemp. ÷ 0.5°	4 —
"M. Sars" St. 96 (64°58' N. 11°12' W.)	1 —

"Beskytteren" (66°39'4 N. 15°30'5 W.), 240 m. 2 specimens
 Skagestrandsbugt, Iceland, 224 m. 3 —

The specimens at hand are of rather varying size, the largest being 5 cm and the smallest 1.2 cm long, without the tail which is 2—7 mm long. The colour is much different, some of the specimens being pure white and others rather dark reddish brown.

There are 15 tentacles, each with one pair of digits placed close to the base of the tentacle. The calcareous ring (Pl. V, fig. 15—16) consists of 10 pieces, of which the radials are supplied with rather well developed bifurcate projections of nearly the same length. The exterior side of the ring itself is deeply sculptured, as the insertions for the tentacle muscles are very deep, and the crests between them form distinct canals for the tentacle-ampullae. The muscular processes are imperforated in all the specimens.

There is one polian vesicle, a long and thin stonecanal with a large madreporite and a distinct porecanal which opens on the body-wall close behind the gonoporus. The alimentary canal is fastened by the mesenteries in the usual three interambulacra, and the anterior loop is very close to the calcareous ring. The respiratory trees are well developed, the right one being the longer, reaching to the calcareous ring to which it is fastened. In all the specimens except the two largest ones the gonads are quite undeveloped, but however paired and branched. The anal papillae are well preserved in some of the specimens. There are five, and as far as can be seen they are undivided.

A feature which ought to be mentioned, is that the longitudinal muscles in one of the specimens are not distinctly paired, but coalesced from the middle of the body and to the calcareous ring. Probably, this is only an abnormality. Retractor-muscles are absent.

The anchors (Textfig. XII, 2—4, 8 & 22) are usually more or less damaged. They have the arms serrate, with up to seven teeth on each. The stem is composed of three rods, which in the distal $\frac{4}{5}$ are totally coalesced. At the base the three rods are visible. The base is a little disk with six round holes, the three of which, those between the traces of the stem-rods, are the largest. The rosettes consist of 5—6 spatulate (racquet-shaped) plates (Textfig. XII, 1, 7 & 21—22) which are normally 5—700 μ long. They are of much varying size, some of them being often not more than 2—400 μ . Often all the plates of a rosette may be more or less reduced, and in a few cases they may be quite rudimentary (Textfig. XII, 22). Even when the racquet-shaped plates are rudimentary the corresponding anchors are fully developed. In 1908 Clark states that the racquet-shaped plates of the *Ankyroderma* species may disappear in older specimens and be transformed into red phosphatic bodies. This is not seen in the present species, where phosphatic bodies are very rare and only faintly developed (all the specimens at hand are also very young), and the rudimentary rosette-plates mentioned, are never attacked by phosphatic bodies. Furthermore, the rudimentary plates are most common in the smallest specimens, close to the ends, and most likely they may be regarded as juvenile forms. In 1910 Mortensen mentioned a racquet-shaped plate with the distal end somewhat bifid. Such plates are rather common, and the furcation may in some plates reach to the perforated inner part.

The tables of the body-wall are very different. In the medial part of the body-wall they have nearly all three holes (Textfig. XI, 1, 3 & 5), but some few with four holes may be found. The most regular tables have three equally shaped oval holes, but usually the holes are very narrow and often the perforated arm may

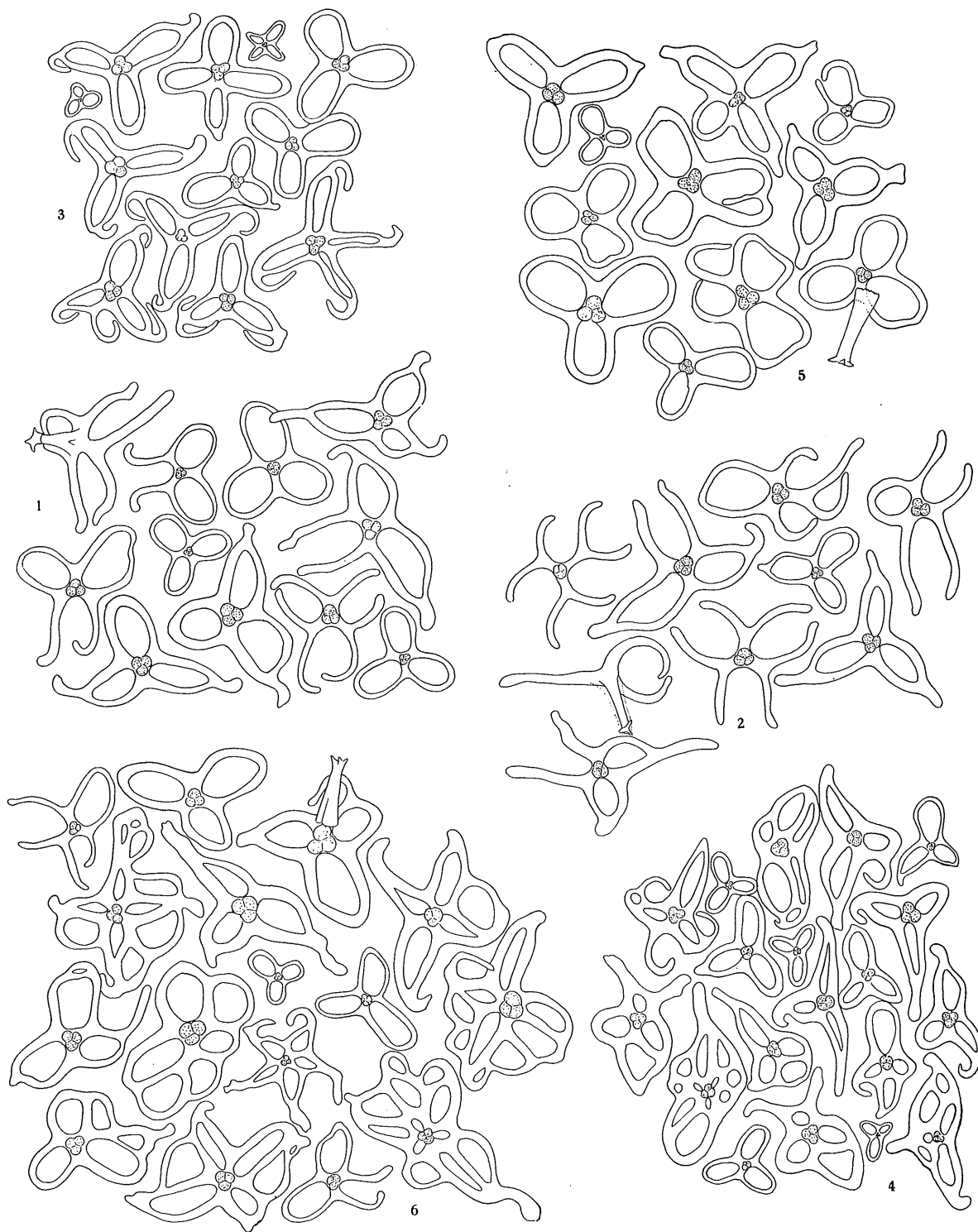

Fig. XI. *Ankyroderma* affine. 1—2. Cotype from "Vöringen", 1 from middle, 2 from posterior end of body. 3—4. Specimen from "Ingolf" St. 4, 3 from middle, 4 from posterior end. 5—6. Type-specimen of var. *groenlandica*, 5 from middle, 6 from posterior end.

be prolonged into a hook (Textfig. XI, 3). The normal size of the plates is 230—250 μ , but some few may be distinctly larger than the others, measuring up to 350 μ . All over the skin some very small tables with the disk measuring only 100—120 μ in diameter are found. In the posterior end of the body-wall, close to the

caudal appendage the shape of the tables is much diverging from what is stated. Normal three-pored tables may occur, but usually there may be 6—12 perforations of different size (Textfig. XI, 4 & 6). As in the medial part of the body minute tables may also be found here.

In the specimens from "Ingolf" St. 4 some very peculiar deposits may be found beside the tables,

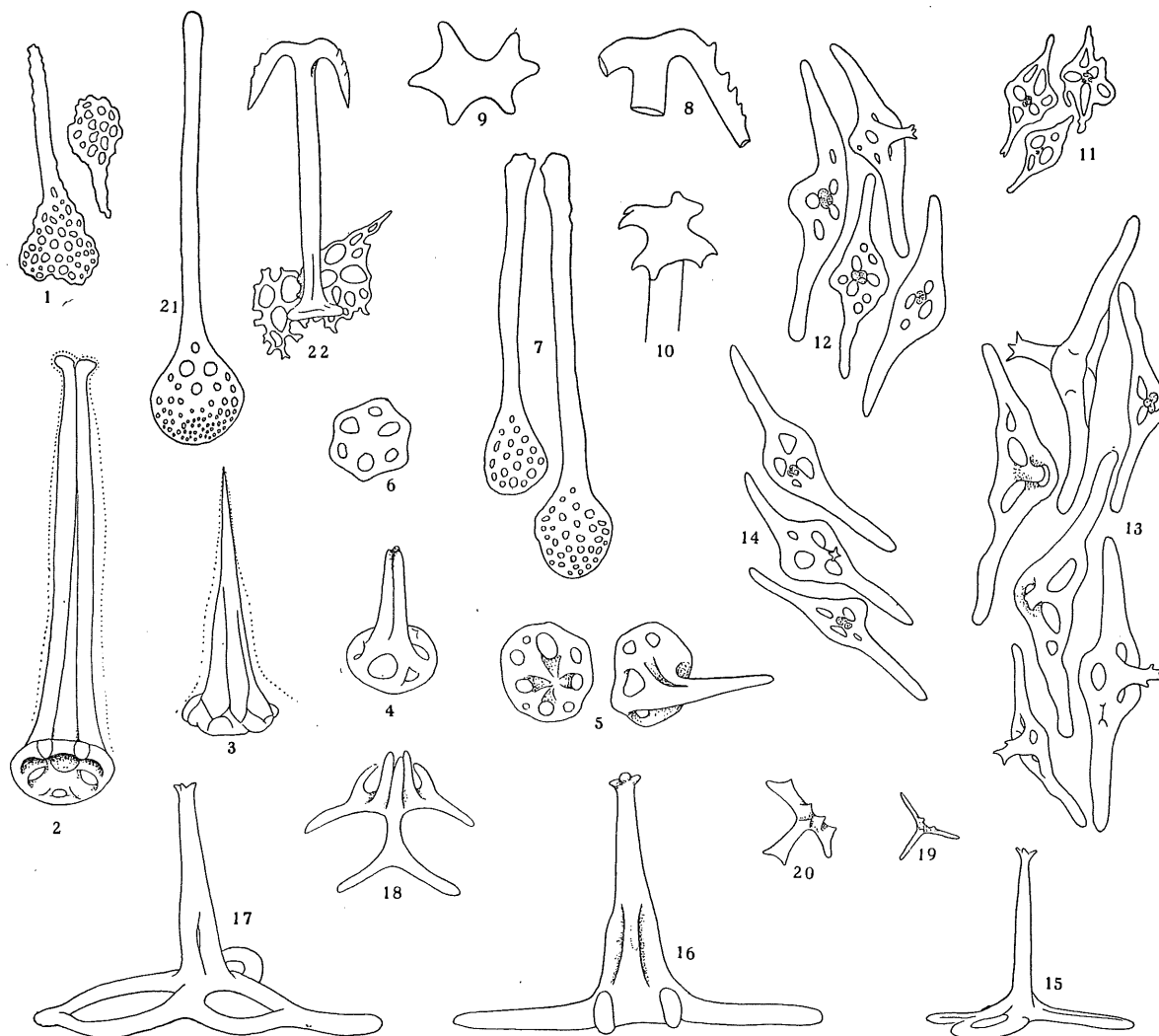

Fig. XII. *Ankyroderma affine*. 1—12. From "Ingolf" St. 4. 1 abnormal racquet-shaped plate, 2—5 different developmental stages of anchor-stem-like deposits from the body-wall. 6 Base of Anchor-stem. 7 normal racquet-shaped deposits. 8 fragment of anchor. 9—10 hooks from the table spire. 11—12 deposits from caudal appendage, 11 the more superficial ones, 12 the deeper ones. 13. Deposits from the caudal appendage of the type of *groenlandica*. 14—22. From the cotype of *affine*. 14 deposits from caudal appendage. 15—17. Different tables with one, two and three rods in the spire. 18—20. Different developmental stage of tables, 21 a racquet-shaped plate, 22 an anchor with malformed plates.

anchors, and rosettes. They are very much like abnormal anchor-stems, but they are never found together with rosettes. Textfig. XII, 2—5 shows such three deposits, which most likely represent three different developmental stages. Textfig. XII, 5 represents two abnormal deposits one of which is only supplied with a rudimentary spire.

In the caudal appendage there are numerous fusiform deposits, usually with a short spire (Textfig. XII, 12—14). A closer examination shows that there are two different sorts of deposits in the caudal appendage,

as some rather small and irregularly shaped ones may be found in the layer of the skin exteriorly to the normal deposits (Textfig. XII, 11).

The specimens at hand agree pretty well with those described by Mortensen in 1910 as *Trochostoma blakei* var. *groenlandica*, and though the general appearance of the deposits from the middle of the body-wall is rather different, that of the deposits from the posterior end is very alike. As Mortensen figured few tables only of the most regular shape, it will be practical to give a figure of the different tables in the two ends of the specimens of var. *groenlandica*.

The determination of the specimens described here has been rather difficult, as they do not agree with any of the descriptions of existing Molpadids. It is evident that they cannot be regarded as a variety of *Tr. blakei* Théel, as this species has no anchors and rosettes. It seemed most reasonable to regard them as a separate species, *groenlandica* Mortensen. For the purpose of drawing the limits between this supposed good species and Danielssen & Koren's two species *jeffreysii* and *affine* Dr. Grieg Bergen was kind enough to lend me some of Danielssen & Koren's specimens of these two species. The examination of these showed that the specimens at hand were distinctly different from *jeffreysii*, but that they must no doubt be referred to the species *affine*, the deposits of which (Textfig. XI, 1—2) agree well with those of the specimens at hand, as well as with those of *groenlandica* which form must be regarded as a variety of *affine*.

In examining the deposits of Danielssen & Koren's specimens, some tables were found lying on the side (Textfig. XII, 15—17), and furthermore some few developmental stages of tables were visible (Textfig. 12, 18—22).

The species *Ankyroderma affine* Danielssen & Koren, is closely related to *Ank. jeffreysii* Danielssen & Koren, and may perhaps prove to be the juvenile stages of this species. For the present however the differences in the shape of the calcareous deposits appear to be so great, that the two forms should be regarded as specifically different.

Genus *Trochostoma* Danielssen & Koren.

Genotype: *Trochostoma thomsonii* Danielssen & Koren.

Diagnosis: Large Molpadids. Body ovoid or sack-shaped, with a short ovoid caudal appendage (i. e. when the caudal appendage is uncontracted). Number of tentacles 15, that of digits three (*Tr. arcticum* is said to have seven digits, but this is not quite certain). Calcareous ring distinctly sculptured, with deep traces of the tentacle ampullae, but in spite of this distinctly different from that of *Ankyroderma*, in which the insertions of the tentacle-ampullae form rather deep canals. Muscular processes of radials often deeply hollowed for the insertion of the longitudinal muscles, but not perforated for the radial nerves. Posterior prolongations of radials of varying size, the ventral one being often nearly rudimentary. The dorsal and lateral prolongations are bent distinctly ventralward. Polian vesicle single and placed at the left radial. Stone-canal long and supplied with a large lateral madreporite and a conspicuous pore-canal, which opens on the dorsal side of the body-wall closely behind the gonoporus.

Calcareous deposits of body-wall only tables, which may often be rod-shaped. Those of the caudal appendage more or less oblong, often nearly fusiform tables. Anchors and rosettes of racquet-shaped plates totally absent, red phosphatic bodies often present.

Remarks: As shown by Hérouard in 1910 and 1923 there is no doubt that the genus *Trochostoma* is a valid genus, distinctly different from the genera *Ankyroderma* and *Molpadia*, and that it is different too from *Eumolpadia* is evident from the discussion of that genus. The best characters for separating *Trochostoma* from *Eumolpadia* are the unperforated radials of the calcareous ring and the absence of large perforated plates in the body-wall, and it is easily separated from both *Ankyroderma* and *Molpadia* by the absence of anchors and rosettes of racquet-shaped plates, as well as by the shape of the calcareous ring.

***Trochostoma thomsonii* Danielssen & Koren.**

Pl. IV, figs. 1—6, Pl. V, figs. 1—5, Pl. VIII, fig. 1.

Trochostoma Thomsonii Danielssen & Koren 1878. Fra den Norske Nordhavsexpedition, Nyt Mag. f. Naturv. Bd. 24, pag. 229.

— — Danielssen & Koren 1882. The Norwegian North-Atlantic Expedition, pag. 42. Pl. VII—IX, fig. 1—41.

Molpadia oölitica part. Clark 1908. The Apodous Holoth., pag. 160.

Trochostoma Thomsoni Hérouard 1910. Sur les Molpadides de Norvège.

— — Hérouard 1923. Holothuries provenant des Campagnes de la Princesse Alice etc.

Localities:

"Ingolf"	St. 59 (65°00' N. — 11°16' W.),	584 m.	Bottomtemp. ÷ 0.1°	1	specim.
—	St. 101 (66°23' N. — 12°05' W.),	1010 m.	—	÷ 0.7°	2 —
—	St. 124 (67°40' N. — 15°40' W.),	932 m.	—	÷ 0.7°	5 —
—	St. 126 (67°19' N. — 15°52' W.),	551 m.	—	÷ 0.5°	2 —
—	St. 138 (63°26' N. — 7°56' W.),	885 m.	—	÷ 0.6°	1 —
—	St. 139 (63°36' N. — 7°30' W.),	1320 m.	—	÷ 0.6°	1 —
"Michael Sars"	St. 34 (62°53' N. — 4°14' W.),	847 m.	—	8	—
—	St. 37 (62°43' N. — 1°26' W.),	753 m.	—	3	—
—	St. 59 (62°40' N. — 1°56' W.),	659 m.	—	÷ 0.5°	2 —
—	St. 96 (64°58' N. — 11°12' W.),	565 m.	—	÷ 0.4°	19 —
"Thor"	St. 51 (66°02' N. — 11°05' W.),	1040—900 m	—	5	—
"Godthaab"	St. 162 (67°48' N. — 60°46' W.),	1600 m.	—	÷ 0.4°	1 —

The specimens at hand measure from 3 cm to 11 cm in length. They are rather different in shape as the narrow neck-like fore-end is more or less protruded, or totally retracted in the body, which is then bluntly cut off anteriorly. Posteriorly the body gradually tapers into the contracted caudal appendage. Only in a single specimen from "Ingolf" St. 126 is the caudal appendage uncontracted, and in this specimen therefore distinctly separated from the body (Pl. IV, fig. 5). This uncontracted caudal appendage has the walls so thin that the radial nerves and the water-vascular system are seen through it. It measures a little more than one tenth of the length of the body proper (10 cm) being 13 mm long with a diameter of about 7 mm.

On account of the varying number of phosphatic bodies, the colour of the specimens is exceedingly different. Some specimens are of a pure yellowish grey, often with a faint greenish tinge, others have the same colour, but are finely dotted with very small purple dots, and in a few specimens these dots are lying so densely

that the colour of the specimens may be brownish purple. In such cases the longitudinal muscles are seen as pale stripes, as the purple dots are usually more sparse in the radii than in the interradii.

There are 15 tentacles, which in nearly all the specimens are totally retracted into the peristome. In the few specimens where they can be examined, they are trilobate, having a large digit on each side of the tentacle-stem.

The calcareous ring is more or less distinctly triangular. It consists of 10 pieces, the radial ones of which are supplied with one posterior and two anterior prolongations. The posterior prolongations are of different size, that of the ventral radial always being the shorter. The two dorsal as well as the two lateral ones are bent toward the little ventral prolongation. All five processes are usually supplied with enlarged bifid ends, but the furcation of the ends may often be rather faint, and in some cases, when the midventral process is rudimentary, it may be totally undivided. The two anterior processes of the radial pieces are always of different size, as the muscular processes are much larger than the others. The shape of the muscular processes is much varying (Pl. V, figs. 1—2 & 4—5), not only in the different specimens, but also in the single individual, in which the dorsal radials are usually much different from the ventral and especially from the midventral one. The muscular processes are more or less distinctly hollowed for insertion of the longitudinal muscles, and in none of the rather numerous specimens examined perforated for the passage of the radial nerves. On the exterior side of the calcareous ring there are distinct impressions of the tentacle-ampullae, but these impressions are not by far so deep as in *Ankyroderma*.

The radial muscles are paired, and the two corresponding muscles do not unite until above the calcareous ring. No real retractors are developed, but in uniting the muscles form a short triangular "retractor" (Pl. IV, fig. 2) which in somewhat contracted specimens forms an angle to the larger part of the muscle and goes backward, uniting with the muscular process of the radials (cf. Norw. North-Atlant. Exp. Pl. VII, fig. 8 a).

The ring-canal is voluminous and supplied with a large stalked polian vesicle, and a long and thin stone-canal. The latter goes close to the body-wall, where it has a large madreporite and a short and thick pore-canal which opens on the body-wall with a little but distinct pore. In describing this species Danielssen & Koren mentioned this feature, but they have seen it as if the madreporite was placed on the side of the stone-canal, which penetrates into the muscular layer of the body-wall. The opening on the body-surface they did not observe.

As stated in the description of the stone-canal of *Ankyroderma*, the stone-canal may be divided into three parts, the stone-canal proper, the madreporite and the pore-canal. The arrangement of these three parts is usually as follows: the madreporite is lateral, and the pore-canal is placed in the prolongation of the stone-canal proper, but in some cases, especially within the species *Tr. thomsonii*, the madreporite is so highly developed that it appears as being not lateral but placed between the stone-canal proper and the pore-canal, the latter often being very like a prolongation of the madreporite.

The intestine is long and voluminous and forms a large loop. It consists of four parts, which can easily be distinguished with the naked eye. The oesophagus is very thick-walled and more or less dotted with red and white longitudinal spots. It does not reach farther back than to the first third of the length of the dorsal

interambulacrum. From here and to the right ventral interambulacrum the rather slender and somewhat glandular stomach extends. The second descending part of the intestine consists of two parts, a large and exceedingly voluminous part with thin and smooth walls and a much narrower part which in the one side is regularly folded (Pl. IV, fig. 3—4). The length of the folded part may be much different. In some specimens it is only $\frac{1}{2}$ —1 cm long and in others it occupies the two posterior thirds of the second descending part of the intestine.

The mesenteries are large and solid. In the second descending part they are often somewhat reticular or transformed into solid strings. Anteriorly the mesentery begins in the left side of the dorsal interambulacrum (Pl. IV, figs. 3—4). From here it runs toward the right side of the dorsal interambulacrum and a little posterior to the middle of the specimen it reaches to the right dorsal longitudinal muscle. For about one cm it is fastened to the dorsal side of the muscle, there it forms a loop into the interambulacrum again and runs forward until it crosses the left dorsal muscle. Here for a distance it is fastened to the lateral side of the left dorsal muscle, and close to the anterior end of the specimen it crosses the left dorsal interambulacrum, but does not join the left ventral muscles. At this place the real solid mesentery disappears, and the anterior loop of the intestine is fastened to the left ventral as well as to the right ventral interambulacrum by the above mentioned thick threads, which are often united thus forming a reticular mesentery. As far as can be seen these threads are never fastened to the left ventral and the mid-ventral muscles, but the second descending part of the intestine is by thick threads strongly secured to the lateral part of the right ventral muscle. After following this for half to one and a half cm, the mesentery passes over the median part of the muscle running in the right side of the right ventral interambulacrum to the cloaca. Here the mesentery disappears and the cloaca is fastened to the body-wall by thick threads. In the caudal appendage these threads are changed into small exceedingly densely placed threads, which form a nearly spongy layer between the body-wall and the rectum.

The respiratory trees are well developed, and fastened to the body-wall by long threads. The right one is much longer than the left and fastened to the calcareous ring by solid strings.

The gonads are bushy branched. They are placed much posteriorly of the calcareous ring, but the long gonoduct reaches closely behind the tentacles, where it opens with a transverse slit on the body-surface. A genital papilla is totally absent.

The anal papillae can only be examined in the single specimen with the caudal appendage uncontracted. They are irregularly trilobate, and placed direct on the edge of the anus (Pl. IV, fig. 1).

The calcareous deposits (Textfig. XIII & XIV) are irregularly shaped "tables", and only in the anal-papillae small perforated plates are found, which are distinctly different from the other deposits. Anchors and spatulate plates are not found in any of the specimens at hand, and as these have all been carefully examined, such deposits may really be absent in small as well as in large specimens.

The tables are much varying in shape, being now large perforate and stellate plates with a distinct spire, and now irregularly branched rods. As stated by Danielssen & Koren the tables are different at either end of the specimens, but the examination of the specimens at hand furthermore shows that the deposits in the dorsal and ventral side are also different. Textfig. XIII shows the tables from the different places of the

body-wall of the specimen from "Ingolf" St. 139. The rods in the anterior end are very alike on the dorsal and ventral side of the specimen. They form oblong perforated plates and about $400\ \mu$ long, with a rather short

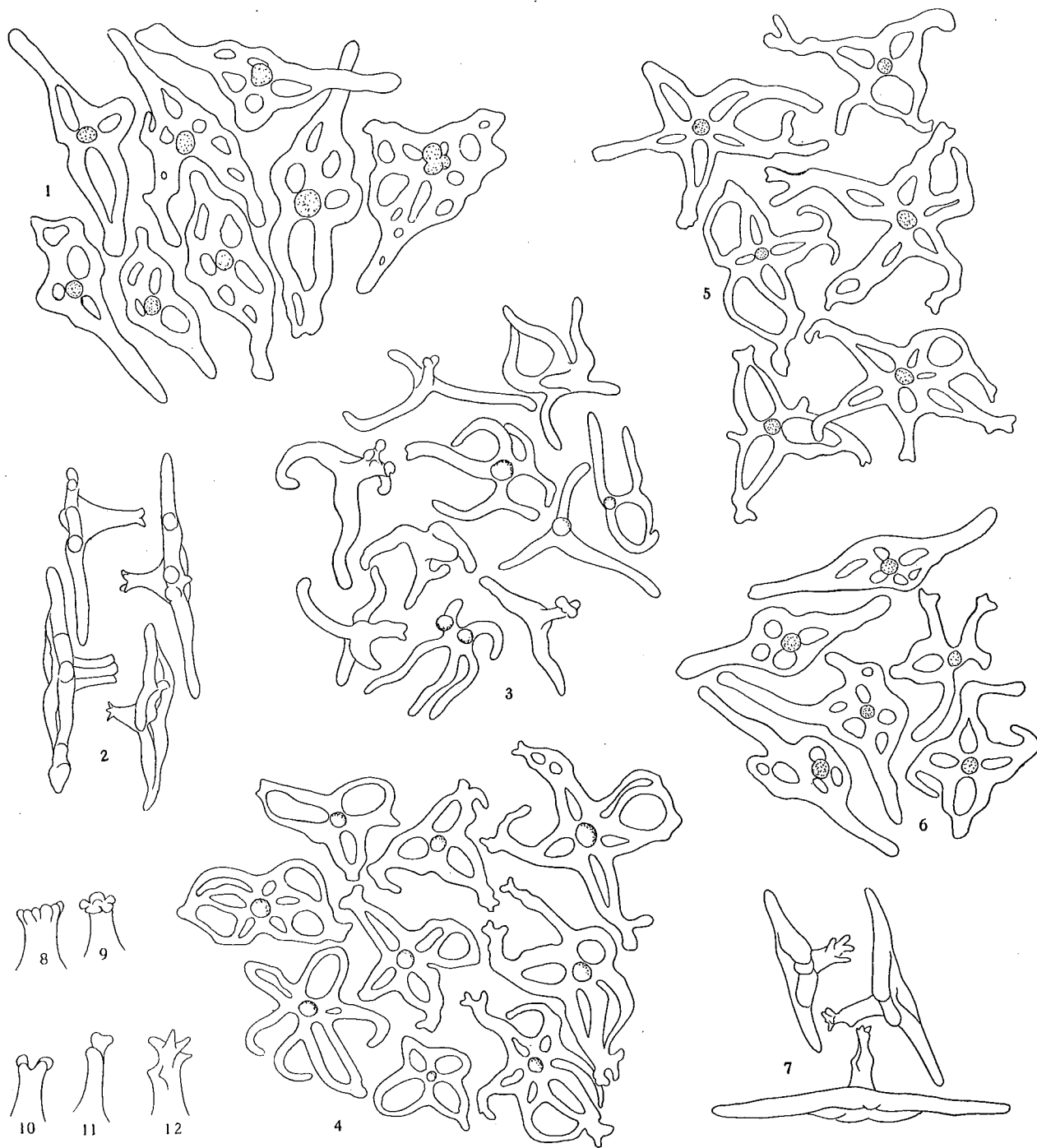

Fig. XIII. *Trochostoma thomsonii*, a specimen from "Ingolf" St. 139. 1—2 from anterior end, 3 from the middle, ventral side, 4 from the middle, dorsal side, 5 from posterior end, 6—7 from caudal appendage. 8—12 different spires.

spire in the middle (Textfig. XIII, 1). The spire usually consists of a single rod only with a little crown of varying shape on the end (Textfig. XIII, 8—12). A closer examination shows that the seemingly simple rod consists of three pieces.

In the middle of the body, the tables in the dorsal side form 3—400 μ large stellate perforated plates (Textfig. XIII, 4) and ventrally 2—300 μ large rods (Textfig. XIII, 3) at the posterior end, close to the caudal appendage, the tables are much like those found in the dorsal side of the middle of the body (Text-

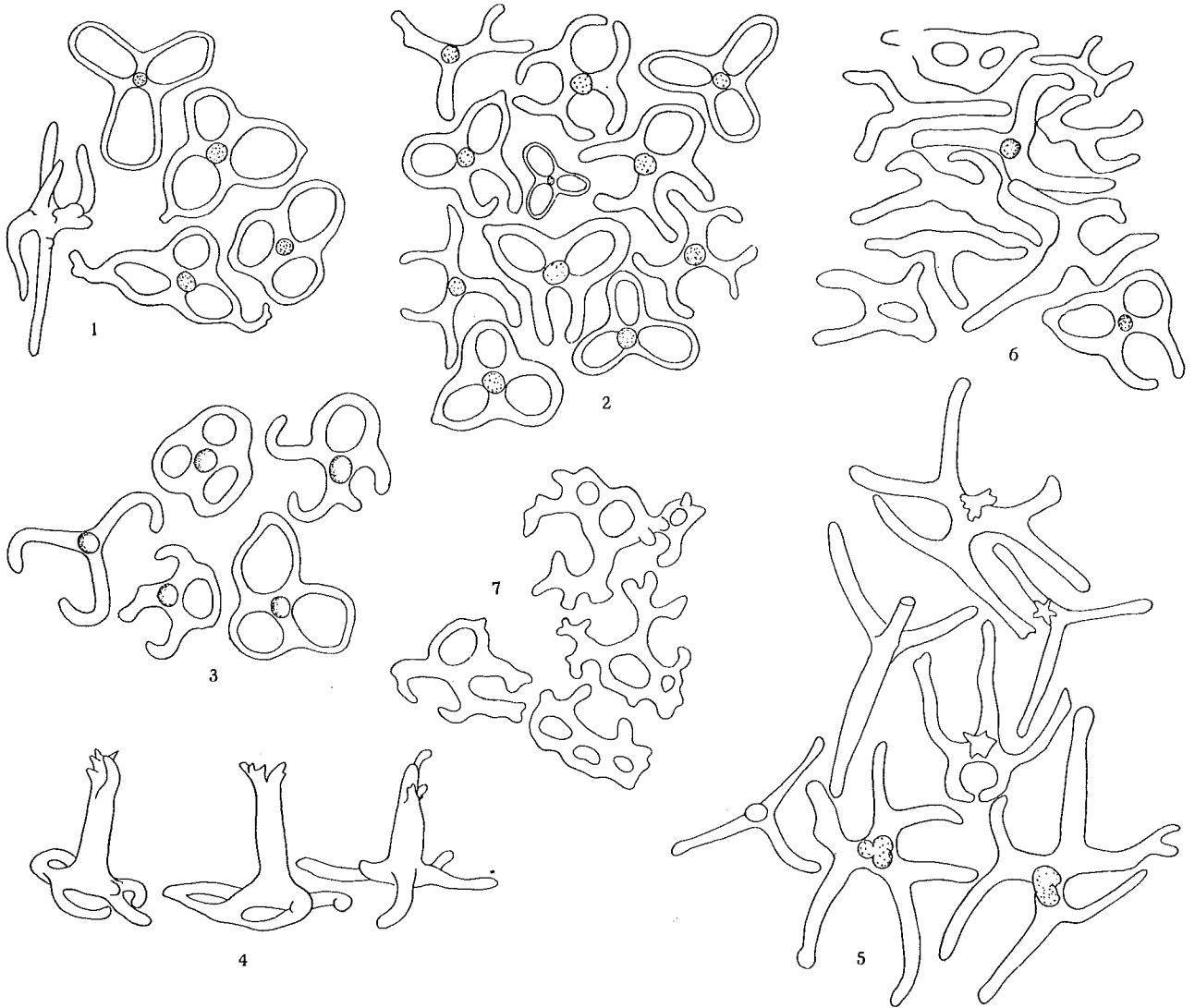
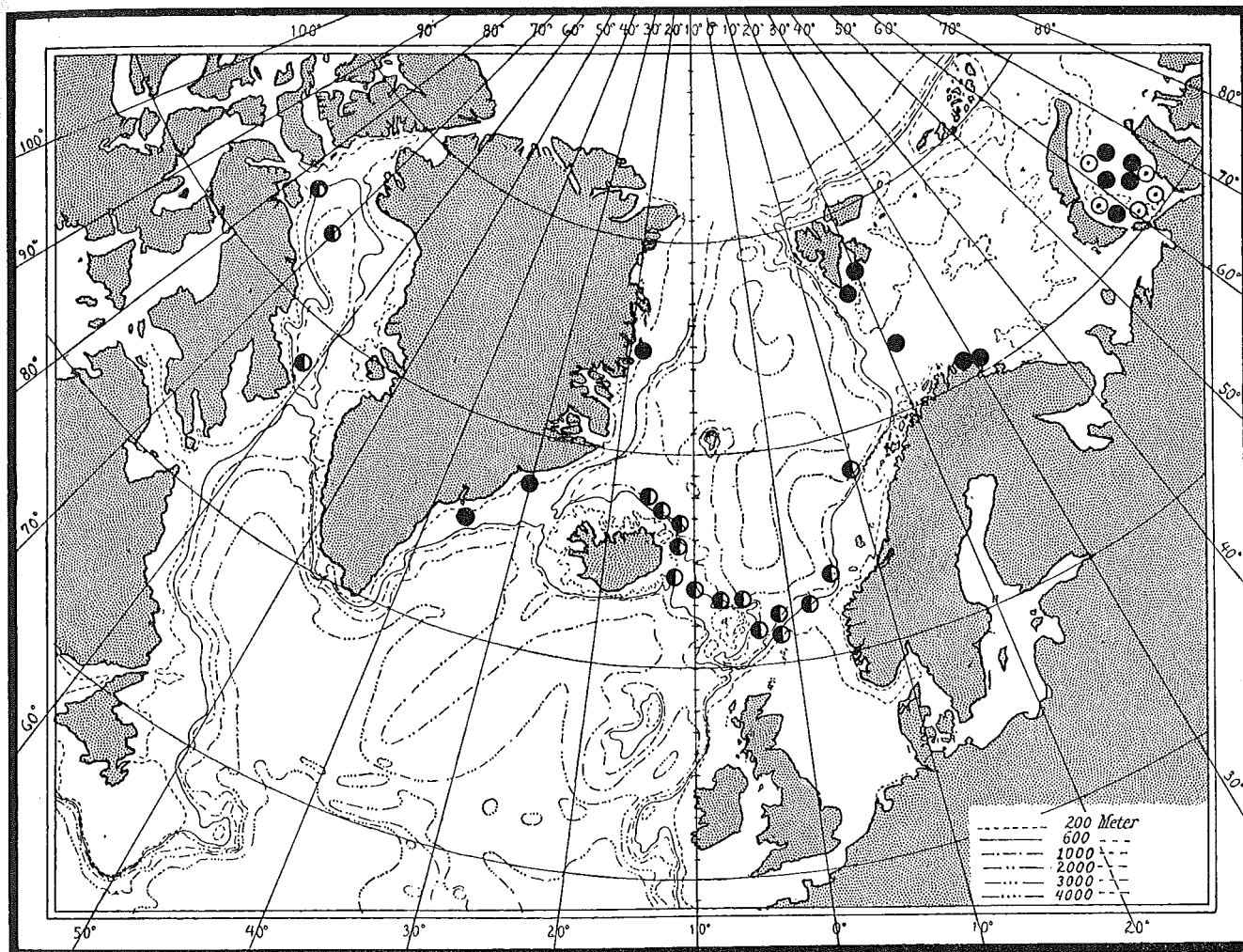

Fig. XIV. *Trochostoma thomsoni*. Deposits of different specimens. 1 from "M. Sars" St. 37 c, 2 "M. Sars" St. 59, 3—4 "Ingolf" St. 124, 5 "Thor" St. 51, 6 "M. Sars" St. 37, 7 rods from the anal teeth of a specimen from "Ingolf" St. 126.

fig. XIII, 5) and in the caudal appendage the rods are rather similar to those from the anterior end, but the spire may be slender and more spinous (Textfig. XIII, 6—7).

In the main, the calcareous deposits in the other specimens agree rather well with those described, though the variation may be considerable. Some few specimens differ however so much that they had better be mentioned specially. The specimens from "Thor" St. 51 differ in having large stellar rods (Textfig. XIV, 5) both ventrally and dorsally. Some few with a single perforation or two may be found, but they are far from being so common as the tables figured. The specimens from "Michael Sars" St. 59 have somewhat smaller rods than the other, and these rods are more or less three-perforate (Textfig. XIV, 2). A specimen from "Michael

Sars' St. 37 is conspicuous, as it has many rodlike tables without spire (Textfig. XIV, 6) and another from the same locality has three-perforate plates between very irregular, rodshaped deposits (Textfig. XIV, 1). Finally a specimen from "Ingolf" St. 124 should be mentioned, as it has unusually long (about 150 μ) and irregularly spinous spires (Textfig. XIV, 4) although it has tables only about 170—250 μ large (Textfig. XIV, 3).



- Tr. boreale
- ◐ Tr. thomsonii
- Tr. arctica

Map. 2. Distribution of the North Atlantic species of *Trochostoma*.

Phosphatic deposits may be totally lacking in some specimens, in others they are however rather numerous. That no classificatory importance can be attached to this is seen from the numerous intermediate stages. As a matter of fact, the phosphatic deposits may be so tiny and so scattered that it is often almost impossible to state whether such deposits are lacking or not.

As to the identification of the specimens at hand there may be no doubt. In spite of the considerable variation in the shape of the calcareous deposits, in the shape of the calcareous ring as well as in the presence of phosphatic deposits I feel convinced that all the specimens at hand are referable to the same species. Perhaps

some of the most deviating specimens may prove to represent separate varieties, but with our present knowledge of this difficult species it is not possible to say anything definite about this. That the species dealt with here is Danielssen & Koren's *Trochostoma thomsonii* is evident, not only from the good agreement with their thorough description of this species, but Dr. Grieg has kindly sent me some of Danielssen & Koren's specimens for a closer comparison. Unfortunately, Danielssen & Koren have not elected any type for the species, but the specimens received from Dr. Grieg were examined and dissected by the said investigators.

On the other hand, it is almost impossible to find any good characters by which *thomsonii* can be separated from *Haplodactyla arctica* v. Marenzeller and *Molpadia boreale* M. Sars, when the specimens at hand are compared with the literature. Clark separates *thomsonii* and *arctica* by means of the presence or absence of phosphatic deposits. As stated above this character can not be used, because these deposits may be totally absent even in good specimens of *thomsonii*; and owing to the presence of phosphatic bodies in both *thomsonii* and *boreale* Clark regards these two species as synonyms. The present material, however, includes some specimens which according to the locality and the differences from the species here described, should more reasonably be regarded as representing the two said species, and as shown in the description it is possible to separate all the three North-Atlantic *Trochostoma*-species by means of the shape of the calcareous deposits and the calcareous ring.

An interesting feature is the different localities in which *thomsonii* and *arctica* are found. All the specimens known of *thomsonii* are taken from localities with a very low temperature at the bottom ($\div 0.5^{\circ} \pm 0.2^{\circ}$ C.) and those of *arctica* from localities with more shallow water and a higher temperature $+ 2-5^{\circ}$ C., cf. the Map pag. 57.

***Trochostoma arcticum* (v. Marenzeller).**

Pl. V, fig. 8, Pl. VIII, fig. 2.

Haplodactyla arctica v. Marenzeller 1877. Coelent. Echinod. Würmer d. k. k. öst-hung. Nordpol Expedition p. 29.

Trochostoma arcticum Danielssen & Koren 1879. The Norwegian North Atlantic Expedition, pag. 65.

Trochostoma boreale part. Ludwig 1900. Arktische u. Subarktische Holothurien.

— — Mortensen 1903. Echinoderms from East Greenland, pag. 89.

Molpadia arctica Clark 1908. The Apodous Holothurians, pag. 169.

— — Mortensen 1910. Report on the Echinoderms of North-East Greenland, pag. 284—85.

Localities:

Flemming Inlet, North-East Greenland 2 specimens
Kara Sea ($78^{\circ}55'$ Lat. N. $78^{\circ}15'$ Long. E.), 148 m. 5 —

The specimens at hand are of different size, those from Flemming Inlet and the two from the Kara Sea are about 10 cm large, and the three from the Kara Sea are only $1\frac{1}{2}$ —2 cm. The colour is greenish grey, often with dark spots, which most likely originate from bottom-material. There are 15 tentacles, but they are so retracted, that the number of digits cannot be ascertained. According to Danielssen & Koren there are seven digits, but probably this statement is erroneous, as some specimens received from Bergen (determined by Danielssen & Koren) do not appear to have more than three distinct digits. The tentacles of these specimens are however not fully distended, so they may possibly have more than three digits. The

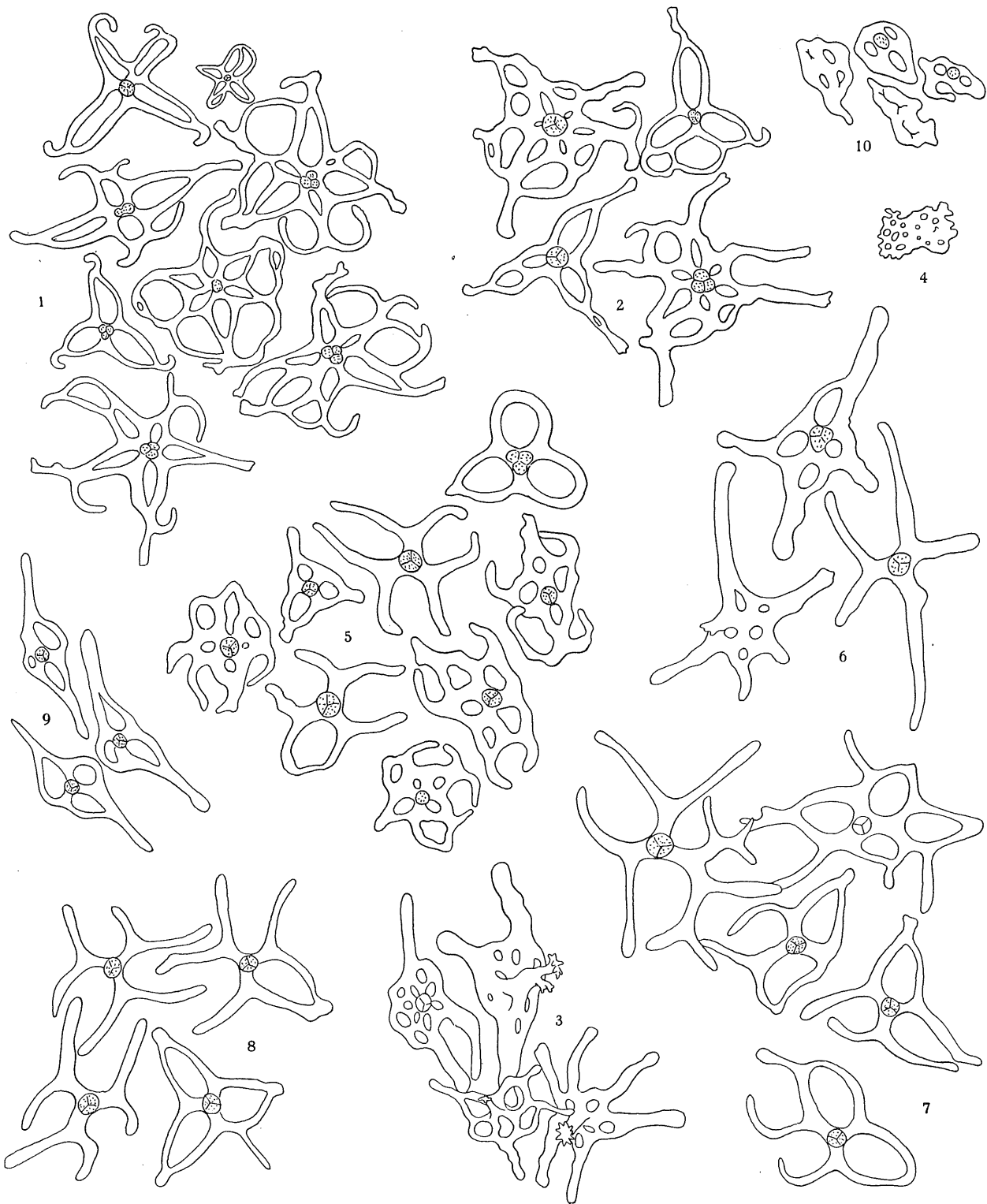

Fig. XV. *Trochostoma arcticum*. 1—4 from a small specimen from the Kara Sea. 1 from the middle, 2 from posterior end, 3 from caudal appendage, 4 from anal papilla. 5 from a large specimen from the Kara Sea. 6—8 from a specimen from Flemming Inlet East Greenland, 6 from the ventral side of the middle, 7 from dorsal side of middle, 8 from anterior end. 9 from anterior end of another specimen from Flemming Inlet.

calcareous ring (Pl. V, fig. 8) rather resembles that of *Tr. thomsonii* and like the latter it has the muscular processes unperforated. The polian vesicle is single, and the stone-canal is long and supplied with a large madreporite and a distinct pore-canal which opens on the dorsal side of the specimens close behind the gonoporus. The gonads are paired and in the large specimens well developed and bushy branched. The intestine has a large loop, and is fastened to the normal three interradial by the mesenteries (Pl. VIII, fig. 2). The respiratory trees are well developed, and as usual the right one is the larger and most branched.

The calcareous deposits (Textfig. XV) are very different in the specimens at hand, but in each individual they are not as varying as in the specimens of *Tr. thomsonii*. They are irregularly shaped tables with a rather short spire. In a few cases the plates are rod-shaped, but usually they are supplied with three to twelve perforations. In the caudal appendage there are also small but very irregular plates (Textfig. XV, 3), and in the anal papillae there are minute perforated plates (Textfig. XV, 4). Phosphatic deposits are totally lacking in all the specimens at hand, and they are always stated to be absent in this species.

Trochostoma arcticum is most closely related to *Tr. thomsonii* and can only be separated from it with great difficulty. Probably, the two species are really synonymous, but for the present it is impossible to state anything with certainty. It was previously supposed that the presence or absence of phosphatic deposits was a feature usable for separating these two species. The variation in the presence of these deposits in *thomsonii* however, shows that though red bodies are really always lacking in *arcticum*, this feature cannot be used for separating the species. The differences in the shape of the calcareous ring seem to be characteristic, but the differences in this feature are not much greater than they may be among different specimens of *thomsonii*. From *Tr. boreale* (Sars), *arcticum* is distinctly different, and these two species can never be confounded. The differences in the shape of the calcareous ring appear to be characteristic, though they are certainly not much stronger than the variation within the species *thomsonii*. In the shape of the deposits *boreale* and *arcticum* appear to be clearly different, and ought not to be confounded.

Trochostoma boreale (Sars).

Pl. V, figs. 6—7, Pl. VIII, fig. 3.

Molpadia borealis Sars 1859. Om tre nye Holothurier etc. p. 174. Vid. Selsk. Forhandl. Christiania.

Trochostoma boreale Danielssen & Koren 1882. The Norwegian North Atlantic Expedition, pag. 64.

— — Levinsen 1887. Kara-Havets Echinodermata, pag. 388.

Molpadaia oölitica part. Clark 1908. The apodous Holothurians, pag. 160.

Localities:

The Kara Sea, different stations of "Dijmphna" numerous specimens.

The specimens at hand are those described by Levinsen in "Dijmphna-Togettets zoologisk-botaniske Udbytte". Unfortunately, they are all preserved in acid alcohol, which has almost totally dissolved the calcareous deposits. A large specimen however contains such remains of the deposits, that a few can be drawn (Textfig. X, 1—2), and from an old microscopical preparation some others can be drawn (Textfig. XVI, 3). As seen from the figures the deposits of the two specimens are very different in shape, there being tables with perforated plates in one, and rodshaped tables in the other. Probably, the material at hand includes more than one form, the shape of the specimens, and apparently also that of the calcareous rings, is somewhat

differing. Unfortunately, also most of the calcareous rings are attacked by acid to such an extent, that it is impossible to clean them for drawing purposes. The figures (Pl. V, fig. 6—7) show the ring of the same speci-

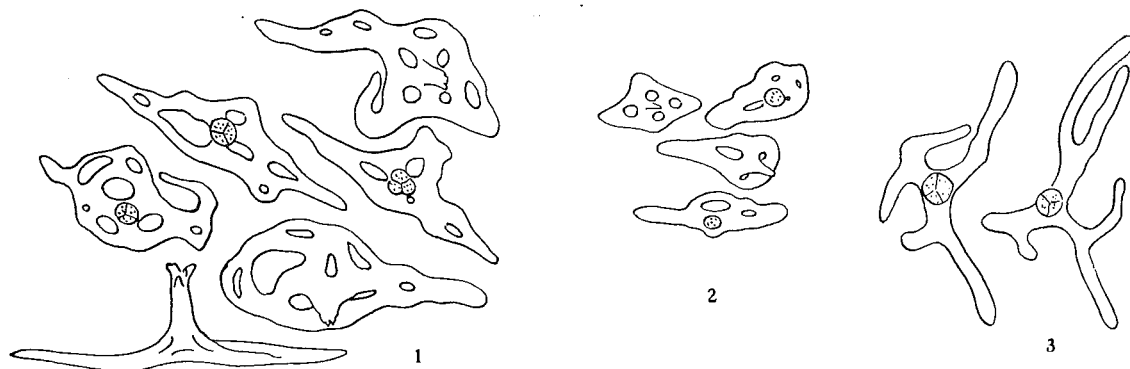

Fig. XVI. *Trochostoma boreale*. 1—2 from the large specimen with the figured calcareous ring, 1 from the middle of the dorsal side, 2 from anterior end, 3 from an other species from the Kara Sea, probably an other species.

men as that from which the deposits (Textfig. XVI, 1—2) are taken. This specimen further differs from the other specimens in the shape of its body, this being more oblong.

Though the material at hand does not allow a description of *Tr. borealis*, it is seen, that this species is distinctly different from both *arcticum* and *thomsonii*. It is most closely related to *thomsonii*, with which it quite agrees in anatomical details.

Family Caudinidae Heding 1931

(= *Molpadiidae* Östergren 1907).

Diagnosis: Molpadids of moderate or large size. Tentacles normally 15. Number of digits varying from 0—4. Radials of calcareous ring with posterior prolongations. Perforations for the passage of the radial nerves absent. Longitudinal muscles paired and often with distinct retractors. Respiratory trees paired and much branched. Caudal appendage of different size, being exceedingly long in the genera *Caudina* and *Paracaudina*¹⁾, short in *Aphelodactyla* and totally absent in *Acaudina*.

Calcareous deposits small tables with a spiny spine, irregular perforated plates or "buttons". Anchors and racquet-shaped plates as well as fusiform bodies absent. Calcareous deposits often apparently absent in mature specimens, but even then usually present close to or in the caudal appendage. Phosphatic deposits absent (except in one rather unknown species *C. pigmentosa* Perrier).

Remarks: The family *Caudinidae* is identical with Östergren's family *Molpadiidae*, but the name has been changed as Östergren, erroneously, has followed Johs. Müller in using the generic name *Molpadia* for *chilensis* and *coriacea*.

In the Monograph on the Apodous Holothurians Clark has not adopted Östergren's division of

¹⁾ This genus was erroneously named *Pseudocaudina* in my preliminary note. As stated in my paper *Paracaudina* nom. nov. the name *Pseudocaudina* was preoccupied for a fossil Zoanthid.

the Molpadids into three families, as he did not consider the differences in the shape of the calcareous deposits and in the arrangement of internal anatomy to be of sufficient classificatory value. There is however no doubt that all the genera collected in this family differ so distinctly from those belonging to the family *Molpadiidae* that they can not belong to the same natural group.

Of the four genera belonging to the family *Caudinidae* only one (the genus *Caudina* Stimpson) is from the Atlantic Ocean, and may thus be included in the collections dealt with in this paper. The three other genera are all from the Pacific and the Indo-Pacific Ocean. Further the genus *Haplodactyla* is previously placed here.

Genus *Caudina* Stimpson 1853.

Genotype: *Chirodota arenata* Gould.

Diagnosis: Tentacles 15, each with four terminal digits of equal size. Calcareous ring with large posterior prolongations on the radials, and with muscular processes unperforated. Retractor-muscles absent. Caudal appendage long and slender. Right ventral mesentery either lacking or rudimentary and replaced by two rows of strong threads fastening the second descending part of the intestine to the body-wall.

Deposits tables with rather robust spiny spire. "Cup"-shaped bodies (i. e. incompletely developed tables) may occur, especially in old specimens.

Remarks: The genus *Caudina* as described here differs distinctly from the two genera *Paracaudina* and *Haplodactyla*. The best character by which the three genera can be separated appears to be the calcareous deposits. Through these it is evident that *Paracaudina* is more closely related to the older genus than is *Haplodactyla*, as the two first named genera have their deposits originating from a real primary cross, and *Haplodactyla* have its tables formed at first as a little three-armed star.

Caudina arenata (Gould).

Pl. V, figs. 18—19, Pl. V^{III}, fig. 9.

Chirodota arenata Gould 1841. Report on the Invertebrata of Massachusetts etc., pag. 345.

Caudina arenata Stimpson 1853. Synopsis of the Marine Invertebrata of Grand Manan etc., pag. 17.

- — Théel 1886. The Challenger Holothurioidea II, pag. 54.
- — Gerould 1895. The Anatomy and Histology of *Caudina arenata* Gould, pag. 123—190, Pl. 1—8.
- — Clark 1908. The Apodous Holothurians, pag. 174.
- — Hérouard 1923. Holothuries provenant des Campagnes de la Princesse Alice et l'Hirondelle II, pag. 139. Pl. III, fig. 3 & Pl. V, fig. 9.
- — Deichmann 1930. Holothurians of the Atlantic Ocean, pag. 200, Pl. 24, fig. 2—5.

Locality:

Massachusetts 5 specimens

Caudina arenata is not included in the collections of the Ingolf, being a shallow-water species, but as it is from the North-Atlantic, and some well preserved specimens of it are contained in the collections of the Zoological Museum of Copenhagen, it should be briefly mentioned here.

The specimens at hand are rather large, the largest being 11 cm and the smallest about 4 cm long. The shape of the body is somewhat differing from that of the body of *H. albicans*. In *albicans* the body proper is distinctly set off from the long and very thin caudal appendage, and in *arenata* the body is gradually tapering into the rather short caudal appendage. The tentacles are quite like those of *albicans*, and as in that species only partly retracted.

The calcareous ring is very different from that of *albicans* as the insertions of the tentacular muscles are placed much more posteriorly (Pl. V, figs. 18—19). Insertions for tentacle-ampullae are not distinctly set off from the muscular insertions. As Hôzawa in 1928 (On changes occurring with advancing age in the calcareous deposits of *Caudina chilensis* (J. Müller)), showed that in young and older specimens of *Caudina* (= *Paracaudina* Heding) the shape of the calcareous ring may be rather varying, the calcareous ring has been more closely examined in the largest and smallest specimens at hand. In contrast to "*Caudina chilensis*", the calcareous ring of the two specimens are quite alike (Pl. V, figs. 18—19).

The stone-canal is short and supplied with a large madreporite. A pore-canal is absent. Apparently, some faint rudiments of an "axial organ" are present, but owing to the preservation of the specimens it is impossible to ascertain this with certainty.

The mesentery (Pl. VIII, fig. 9) is very interesting. As described by Gerould a normal mesentery is lacking in the right ventral interambulacrum, and the second descending part of the intestine is fastened to the body-wall by two rows of solid strands. These strands are placed in such a way that they are fastened to the lateral side of the right and the left ventral longitudinal muscle respectively, and thus the right row represents the lacking right ventral mesentery. The respiratory trees are much branched, and the right one is the longer.

The longitudinal muscles are paired, and retractor-muscles are lacking. The gonads are well developed in the large specimens, and the gonoduct ends on a distinct genital papilla.

The calcareous deposits are rather alike in the whole body, and even those in the caudal appendage do not differ from the others. They are more or less regularly shaped small tables with a short and thick spire (Textfig. XVII, 3). The deposits of the specimens at hand agree rather well with Gerould's figures (Pl. 3 fig. 17—18 and 26—33) and as figured by Gerould the spire is composed of four rods. The deposits in the small specimen at hand (Textfig. XVII, 3) differ from those in the other specimens as well as from Gerould's figures in being much more regularly formed. Especially one of the deposits found in this specimen is nicely shaped, being nearly skeleton-like. From this it is seen that the ideal *arenata*-table is composed of an almost circular plate supplied with one large central perforation, covered by the spire, and eight marginal holes of varying size, the four opposite the trace of the spire-rods being smaller than the others. This ideal plate is more or less transformed, changing into different irregularly placed holes, in becoming an irregular margin, and, especially in old specimens with many deposits, in being incompletely developed. Thus the small deposits which are usually mentioned as "buttons" cannot be regarded as a separate form of deposits, but as incompletely developed tables.

As to the determination of the specimens at hand there is no doubt that they represent the same species as that described by Gerould and according to the locality also Gould's *arenata*. It is more difficult

to say whether they represent the same species as the specimens described by Deichmann in 1930. In comparing Deichmann's figures with the specimens at hand, as well as with Gerould's figures, one may be inclined to suppose that they belong to another species. Particularly the presence of rather regular fourholed knobbed "buttons" in Deichmann's specimen gives rise to the supposition that she has had to deal with

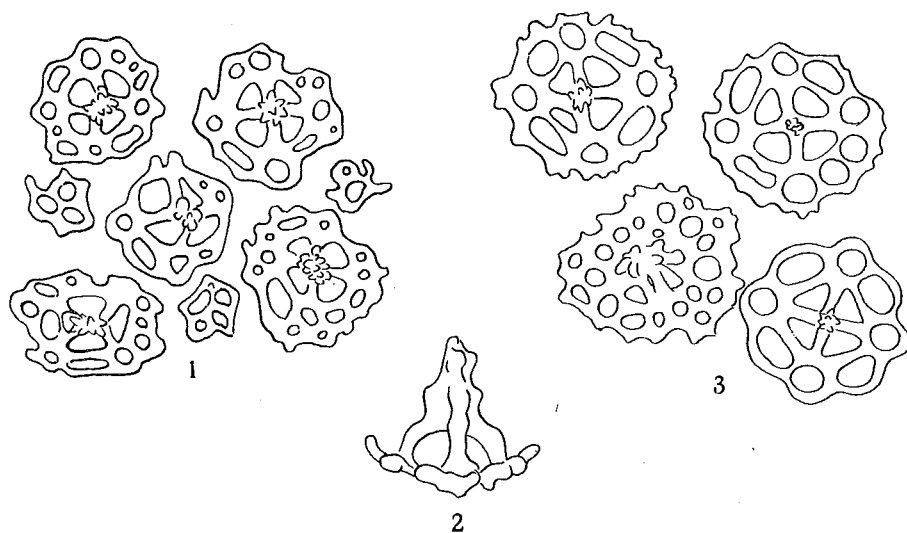

Fig. XVII. *Caudina arenata*. 1—2 from the large specimen, 3 from the little.

a separate species. On the other hand, when Deichmann's figures of *arenata* are compared with her figures of other Molpadids, and further when the specific variation is taken into consideration, there are no positive reasons for doubt.

That Hérouard's record of *arenata* from the large depths of the Atlantic requires confirmation is evident. Furthermore Hérouard's figures differ so much from the specimens at hand, that there is little doubt that his specimen represents a separate species.

Genus *Haplodactyla* Grube 1840.

Haplodactyla Grube 1840. Aktinien, Echinodermen und Würmer des Adriatischen und Mittelmeeres, pag. 42.

Trochostoma part. Théel 1886. The Challenger Report Holothurioidea II, pag. 44.

Caudina part. Clark 1908. The Apodous Holothurians, pag. 172.

Trochostoma Baldelli 1914. Asteroidi, ophiuroidi, crinoidi, olothuroidi etc. pag. 105.

Caudina part. Heding 1931. On the Classification of the Molpadids, pag. 283.

Non.

Haplodactyla Semper 1868. Die Holothurien, pag. 41.

— Ludwig 1892. Die Seewalzen, pag. 353.

— Sluiter 1901. Holothurien der "Siboga" Expedition, pag. 117.

— Koehler & Vaney 1908. "Investigator" Littoral Holothurioidea, pag. 44.

— Heding 1931. On the Classification of the Molpadids, pag. 280.

Genotype: *Haplodactyla mediterranea* Grube = *Trochostoma mediterranea* Baldelli.

Diagnosis: Tentacles with two pairs of digits. Caudal appendage long and slender. Retractor muscles absent. Second descending part of intestine with two mesenteries, being more or less thread-shaped or reticulate. Calcareous deposits tables with perforate plates and spires composed of three rods.

Remarks: There can be no doubt that this genus must be separated from the genus *Caudina*, as the different development of the tables indicates a very important difference. In the genera *Caudina* and *Paracaudina* the tables or buttons originate from a more or less distinct primary cross, and the tables of this genus originate from a three-armed star. This affords to the fully developed deposits the very characteristic feature, that the centre of plate has three central-holes in *Haplodactyla* and four in *Caudina* and *Paracaudina*.

The scarce material at hand does not allow a reliable reference of this genus to the *Caudinidae*, as the stone-canals are so thin that their connection to the body-wall cannot be made out. The general appearance of the specimens, as well as the fact that the best known of them have hitherto been placed close to *C. arenata*, make it most practical to place this genus within the *Caudinidae* until some better specimens are available.

The genus includes for the present only the two allied species *mediterranea* Grube [Baldelli] and *albicans* (Théel), but no doubt it will prove to contain also some of the other species now referred to *Caudina*, as e. g. *californica* Ludwig.

As to the name there can be no doubt that *Haplodactyla* can be used for it. Certainly we do not know much of Grube's *mediterranea*, the only certain thing being that it was found in the Mediterranean. The type has disappeared, according to Grube, and as we know for the present two different forms of Molpadids from the Mediterranean, it lies near to suppose, that one of them is that found by Grube. As further this one is named by Grube's name *mediterranea*, and as shown above must be regarded as belonging to a separate genus, we have here an opportunity of realizing what is meant with the often abused name *Haplodactyla*.

Haplodactyla albicans (Théel).

Pl. IV, fig. 9, Pl. V, fig. 17, Pl. VIII, fig. 10.

Trochostoma albicans Théel 1886. Challenger Holothurioidea II, pag. 44, pl. III & pl. XI.

Caudina albicans Clark 1908. The Apodous Holothurians, pag. 174.

Molpadia albicans Mortensen 1927. British Echinoderms, pag. 421—23.

Localities:

"Ingolf" St. 39 (62°00' N. 22°38' W.), 1628 m. Bottomtemp. 2.9° 1 specimen.
 — St. 40 (62°00' N. 21°36' W.), 1590 m. — 3.3° 2 —

The specimens at hand are only small, and according to their undeveloped gonads they may be juvenile specimens. The largest one, that from St. 39, measures 45 mm including the 24 mm long caudal appendage, and the smallest one only measures 18 mm in body-length, the caudal appendage is lacking. The third specimen measures 30 mm in length (= 19 + 11 mm) and thus it has the caudal appendage relatively shorter than the large specimen. This difference may for a great part be due to contraction of the caudal appendage, but as also the caudal appendage of the large specimen is somewhat contracted, the difference cannot be ascribed to the contraction alone.

There are 15 tentacles, each with four terminal digits. In all the specimens the tentacles are highly contracted, but they are neither retracted in the peristome, nor with this retracted into the anterior end of

the body. The tentacle-muscles are thick and voluminous, and nearly totally fill out the interior of the tentacles. They are fastened to the calcareous ring with conspicuous insertions.

The calcareous ring (Pl. V, fig. 17) consists of ten parts. The interradians are unusually large, and even slightly wider than the radials. The latter are supplied with a short posterior prolongation and two anterior processes of different size. The largest, the muscular process, is slightly hollowed for the insertion of the longitudinal muscles, and a perforation for the passage of the radial nerves is absent. The exterior surface

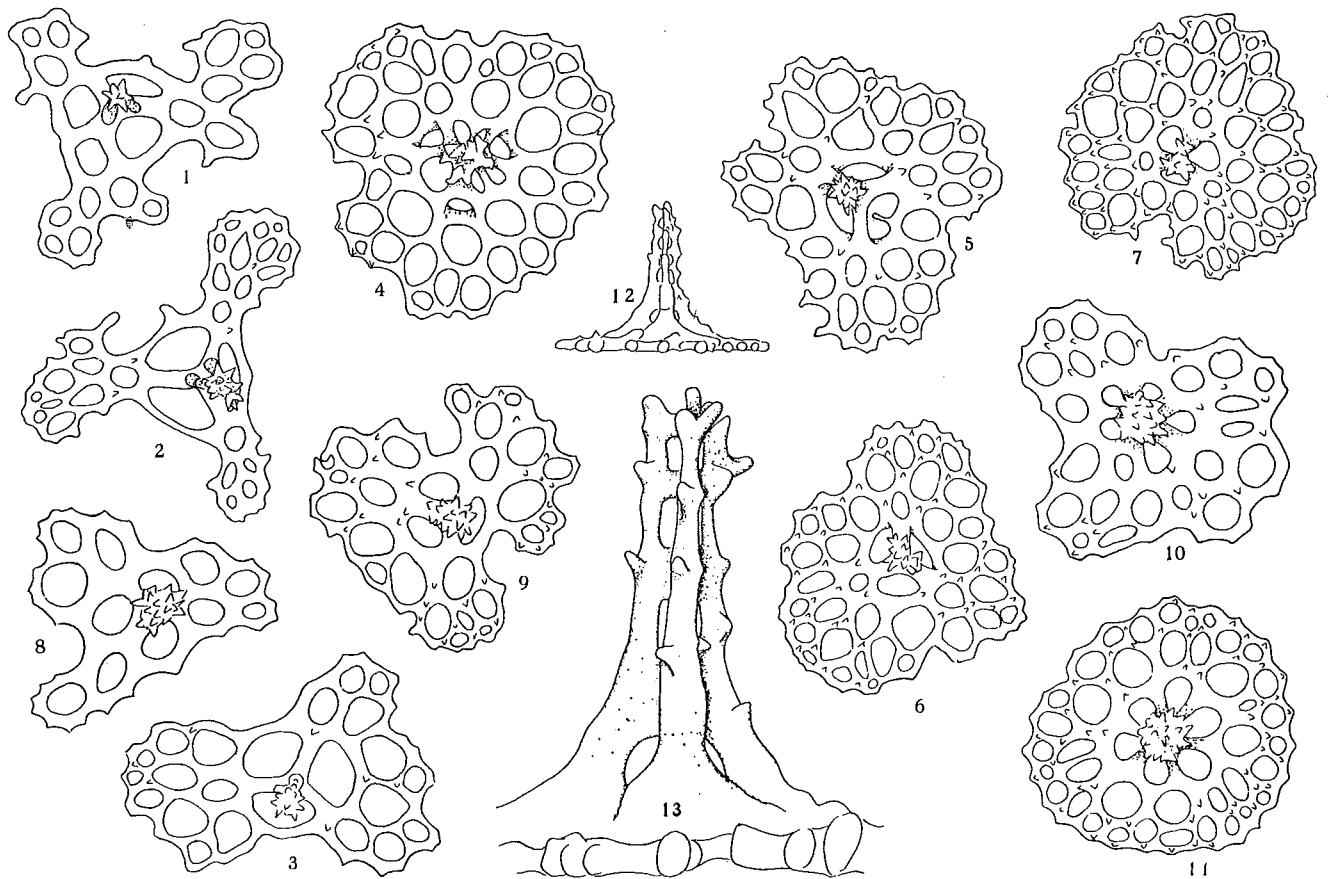

Fig. XVIII. *Haplodactyla albicans*. 1—7 from the specimen St. 39, 8—11 from the specimen St. 40. 12. A table, lateral view. 13. The spire more magnified in order to show the structure.

of the calcareous ring is quite smooth behind the insertions of the tentacle-muscles with very short and faint traces of the tentacle ampullae. There are 15 tentacle ampullae, one on the middle of each radial and two on each interradian.

The exceedingly narrow ring-canal is fastened to the bifurcate prolongations of the radials with rather long "radial" canals. There is one polian vesicle and a short stone-canal with a large madreporite. A pore-canal is apparently absent. The longitudinal muscles are paired and without retractors.

The alimentary canal is rather peculiar. In all three specimens the oesophagus forms a rather large sphere (Pl. IV, fig. 9), and the second descending part of the intestine is unusually voluminous. The mesenteries are well developed and especially the dorsal and the left ones are very conspicuous. Besides by the right

mesentery the second descending part of the intestine is fastened to the body-wall by a row of solid strings, to which the respiratory trees are fastened.

There are two respiratory trees, of which the right is fastened to the calcareous ring. Close to its base the left one is divided into two branches of equal size. It is only half as long as the right one. The gonads are exceedingly small, being only some rudimentary knobs on the dorsal mesentery. Around the anus there are five large anal papillae, each surrounded by numerous small ones, as also mentioned by Théel (Challenger *Holoth.* II, pag. 45).

The calcareous deposits are tables with a perforated, more or less spiny, plate and a high spire. The tables are much different as their plates may be either triangular (Textfig. XVIII, 1-3) or circular (Textfig. XVIII, 11), but as both table forms occur in the same specimen and the three specimens have the tables so much alike, that they are indistinguishable from each other, the triangular and circular shapes of the plates are evidently without any classificatory value. The spire of the tables (Textfig. XVIII, 13) is made up of three separate rods, which are united with three or four "bridges". It is distinctly spiny, even in tables with totally smooth plates.

The deposits in the caudal appendage are quite like those of the body-wall, being spiny tables with a long spire.

There is no doubt that the specimens at hand represent "*Trochostoma*" *albicans* Théel, with which species they agree perfectly.

For the purpose of seeing the true relation between *albicans* and the genotype *mediterranea* Baldelli, I borrowed the type specimen of *Tr. mediterranea* from Italy. There is no doubt that the two species are closely related, as is evident when the figures of *mediterranea* (Textfig. XIX) are compared with those of *albicans* (Textfig. XVIII). It is however not possible to make out the real relation, as Badelli, in examining the type specimen, has removed all organs from the body-wall.

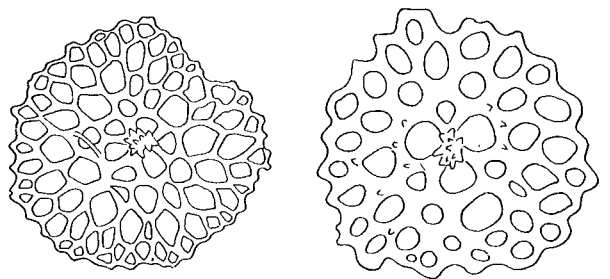

Fig. XXI. *Haplodactyla mediterranea*, the type.

Family Eupyrgidae Semper.

Diagnosis: Molpadids with usually 15 tentacles, with unpaired longitudinal muscles and lacking tentacle-ampullae. Respiratory trees present and often more or less unbranched. Pore-canal present, but in the genus *Eupyrgus* nearly rudimentary.

Remarks: The two genera here referred to the family *Eupyrgidae* are so different that they are united in the same family with much hesitation, but as they both differ distinctly from the two other families of the *Molpadioidea* and in important characters resemble each other it may be practical for the present to keep them together in a separate group.

The absence of tentacle-ampullae and the presence of the unpaired longitudinal muscles place this family rather close to the *Gephyrothurioidea*, and may probably be regarded as very important systematical characters, and perhaps as some rather primitive ones.

As mentioned in 1931 (On the classification of Molpadids) we have reason for supposing that the

Molpadioidea and the *Gephyrothurioidea* are most closely related to the *Synallactidae* which group may be regarded as the most primitive. This was previously pointed out by Östergren in 1907 (Zur Phylogenie und Systematik der Seewalzen, pag. 214). In this paper Östergren considers the Molpadids as a branch of the *Aspidochirota*, and the *Gephyrothuria* as an offshoot from the *Synallactidae*, but he ends his paper with the statement: "Ferner habe ich durch punktierte Linien andere Alternative, . . . , angedeutet". According to the study of the large collection at hand Östergrens figure must be amended as follows.

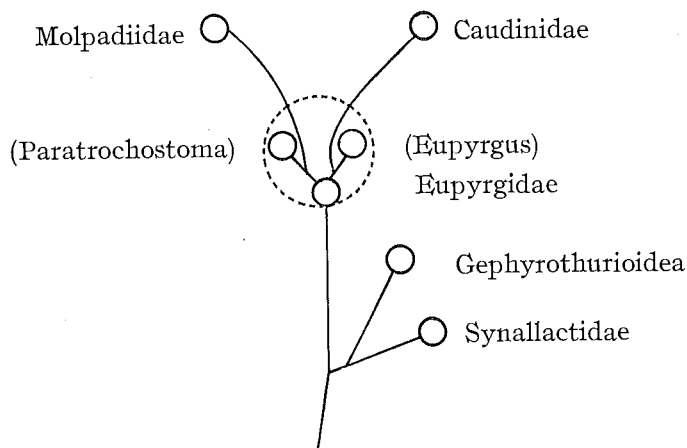

From this figure it appears that each of the two genera united in the family *Eupyrgidae* may be regarded as the ancestral form of one of the two families into which the *Molpadioidea* may be divided, i. e. *Eupyrgus* as that of the *Caudinidae* and *Paratrochostoma* as that of the *Molpadiidae*.

Thus the family *Eupyrgidae* is no natural one, but it may be most practical to maintain it for the present, as the two genera referred to it, being seemingly not more closely related, are both intermediate between the *Molpadiidae* and the *Caudinidae*. It was established by Semper in 1868 for Lütken's genus *Eupyrgus*, but as Semper misunderstood Lütken's description it was placed among the Synaptids. In the cited paper of Östergren the family is placed as the third family of his *Molpadonia*, and in 1908 Clark abandoned it, as he did not suppose it possible to divide the *Molpadioidea* into separate families. As mentioned above it may be most reasonable at present to retain this peculiar and heterogeneous family.

Genus *Eupyrgus* Lütken 1857

(= *Echinosoma* Semper 1868).

Genotype: *Eupyrgus scaber* Lütken.

Diagnosis: Small Molpadids with very short caudal appendage. Tentacles 15. Calcareous ring composed by 10 pieces, of which the radials are distinctly perforated for the longitudinal nerves. Posterior processes of radials either totally absent or very rudimentary. Tentacular ampullae absent. Stone-canal short, madreporite large, apparently terminal and pore-canal long and thin, almost rudimentary. Pore-canal fastened to the body-wall anterior to the gonoporus. Longitudinal muscles unpaired, without retractors. Intestine long and often (always?) supplied with an extra loop. Anal teeth (always?) present.

Calcareous deposits rather large tables with spiny spires. Often more than one size of tables, and no special rods in the caudal appendage.

Remarks: No doubt Semper's *Echinosome hispidum* is the same species as Lütken's *Eupyrigus scaber*, as shown by Clark, and the only reason for Semper to establish a new genus is that he regarded Lütken's species as a Synaptid. Besides Lütken's species this genus only includes the rather unsatisfactorily known Pacific species *Eupyrigus pacificus* Östergren, but some of the specimens referred to *Eupyrigus scaber* may probably prove to represent independent species.

Eupyrigus scaber Lütken.

Pl. IV, figs. 10—11, Pl. VIII, fig. 11.

Eupyrigus scaber Lütken 1857. Grønlands Echinodermata, pag. 22.

Echinosome hispidum Semper 1868. Die Holothurien, pag. 44. Pl. X, fig. 10, 11, 13, 15 & 16.

Eupyrigus scaber Norman 1903. Natural History of East Finmark, pag. 412—13. Pl. XXVII, fig. 1—3.

— — Clark 1908. The Apodous Holothurians, pag. 179. Pl. XII, fig. 16—27.

Localities:

Greenland, Lütken's type specimens	24	specimens
Labrador, Packard 1866	1	—
East Greenland, Hurry Inlet, 18 m. Søren Jensen. ²¹ / ₈ 1900	1	—
West Greenland, Bredefjord 10—15 m, Stephensen. ²⁶ / ₈ 1912	9	—
Nowaja Semlja, Matotschin Scharr, 17—27 m. ¹⁰ / ₈ 1926(?)	6	—
— — Loginow Bay, 20 m. ²¹ / ₈ 1927	1	—
— — — — 75 m. ² / ₉ 1927	1	—

Since Lütken's description of this species in 1857, it is recorded rather often by different investigators, but apart from Semper's description of *Echinosome hispidum* and Norman's figures of the tables of the body-wall, neither tolerably good descriptions nor figures have been given of it.

The specimens at hand are all rather well preserved, but unfortunately the types are so much damaged by earlier investigators (e. g. Lütken) that only the calcareous deposits, the calcareous ring and the anal teeth can be closely examined. The other specimens, especially those from Bredefjord and Nowaja Semlja, are well preserved and allow a closer examination.

The average size of the specimens at hand is ca. 1 cm in length and 0.5 cm in diameter. The caudal appendage is very short in all specimens, being only 1—2 mm. The colour of the specimens in alcohol is either pure white (though in the best preserved specimens yellowish white) or dark black-brown. The examination of the two sorts of specimens has not shown any pronounced difference, only the plates of the tables appear to be a little more irregular in the shape in dark specimens than in the white ones. That the difference in colour is not attributable to the preservation or to different localities, is seen from the specimens from Bredefjord, which were taken at the same locality and are all preserved in the same tube, and which are nevertheless either white or brown.

The body-wall is densely spiny, due to the rather large spines of the tables. A good figure of an intact specimen is given by Norman in 1903 (Pl. XXVII, fig. 1), the figure given by Clark is poor and somewhat misleading. The body-wall is so thin that the longitudinal muscles and often the gonads are visible through it.

The number of tentacles and digits cannot be seen, as the specimens are all rather contracted, but

according to the shape of the calcareous ring, the number of the tentacles is 15. The calcareous ring is rather stout. It consists of 10 pieces, the five radials of which are supplied with two anterior processes and a distinct perforation for the passage of the radial nerves. A posterior process is normally absent, but rather often there may be some rudiments of it, usually on a single of the radials only. Due to the absence of tentacle ampullae, and the insertion of the tentacles in the anterior margin of the calcareous ring, this is lacking all sculptures on the exterior side, and the anterior processes of all the pieces are enlarged to elegant crests between the tentacles (cf. Semper's figure Pl. X, fig. 11).

Tentacular ampullae are totally absent. On the ring canal there is one large polian vesicle and a short stone-canal. The madreporite is often very large, and the long pore-canal is always quite rudimentary. The pore-canal is fastened to the body-wall (a perforation through the body-wall is not observed) anteriorly of the gonoporus.

The radial muscles are unpaired, rather thin and weak not having the faintest trace of a retractor. The alimentary canal is unusually long, and on account of the shortness of the body, it is supplied with two loops. The arrangement of the mesenteries is as follows (Pl. VIII, fig. 11): Anteriorly the dorsal mesentery is fastened to the middle of the middorsal interambulacrum, more posteriorly it bends toward the right dorsal longitudinal muscle. It forms a loop and turning anteriorly it crosses the left dorsal longitudinal muscle. In the left dorsal interambulacrum it turns again and extends nearly in the middle of the interambulacrum, as long posteriorwards as in the middorsal interambulacrum; then again it turns toward the anterior end of the specimen running close to the left ventral longitudinal muscle to rather near the anterior end of the specimen. Here it forms a large loop and crosses both the left ventral and midventral longitudinal muscles. In the right ventral interambulacrum it goes for the third time toward the posterior end of the specimen. In this interambulacrum, it forms a large bow, and running in the middle of the specimen very close to the right ventral longitudinal muscle, it turns again close to the cloaca, toward the midventral longitudinal muscle.

The cloaca (Pl. IV, fig. 10) is well developed and distinctly set off from the intestine. It is fastened to the posterior part of the body-wall by numerous solid strands, and in such a way that it may be more or less retracted. When retracted, the cloaca encloses the posterior end of the intestine, which then forms a large conical papilla into the cloaca. Furthermore the anal opening is withdrawn, so the anal papillae are placed inside of the cloaca. When the cloaca is not retracted, the anal papillae are placed direct on the border of the anal opening.

The respiratory trees are well developed. The right one is unbranched, but supplied with many large bulbs, and almost reaches to the calcareous ring. The left one is much shorter and consists of two branches of equal length. This is contrary to the statements of Clark and Semper, as these authors maintain (and draw) that the respiratory trees are both unbranched, very short only and of equal length. I have therefore examined several of the specimens at hand, and they all have the respiratory trees as here described.

The anal teeth were first mentioned by Semper, who found them in his specimens of *Echinosoma hispidum*, and since then they have not been closely described. Apparently they form a quite unique organ, but a thorough examination shows that they may only be regarded as representing the reticular plates found in the anal papillae of other Molpadids. They are placed exteriorly of the radial canal, and the bifid parts of them

(Pl. IV, fig. 11) are placed over the radial canal, in the same manner as the bifid process of the radials in many Molpadids are placed at the origin of the radial canals.

The gonads are paired and rather branched. The gonoduct is unusually thick and sack-shaped, and especially in female specimens voluminous and uterus-like. The sexes are separate, and the eggs are ripe about August. The ripe eggs measure about $250\ \mu$ in diameter.

The calcareous deposits (Textfig. XX) consist of tables only, with a long and spiny spire. The size and shape of the tables are much varying, but in spite of this, two different sorts can easily be distinguished. The larger sort measures $230\text{--}280\ \mu$ in diameter and has $30\text{--}50$ round holes, and the smaller one

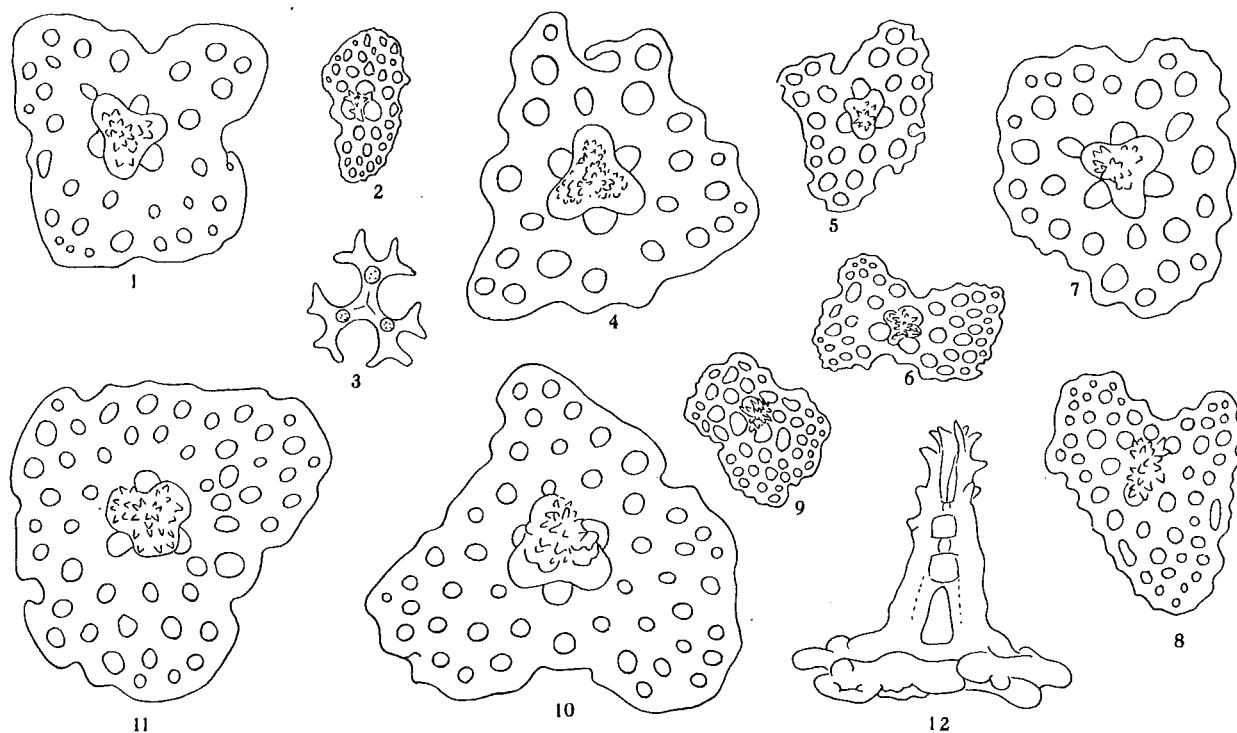

Fig. XX. *Eupyrgus scaber*. 1—7 from the type, 8—11 from a white specimen from Bredefjord. 12. A normal table from the side.

measures $100\text{--}200\ \mu$ in diameter with the same number of holes. The spire is usually of the same height as the diameter of the plate. It resembles the spire of *Haplodactyla albicans* (Théel), and like this it is composed of three separate rods, and supplied with numerous spines.

The figure of a spire given by Clark in 1908 (Pl. XII) is quite misleading, and if it is accurately drawn there is only little doubt that it belongs to another species than *Eupyrgus scaber*. A good figure of the spire of *E. scaber* is given by Norman in 1903 (Pl. XXVII).

E. scaber may be widely distributed in the arctic region, from which it is often recorded. It seems to be circumpolar, but probably the Pacific specimens recorded may represent a separate form. The records of *E. scaber* from the tropical seas must be erroneous, as shown by Clark. The bathymetrical distribution is rather limited. The species is usually found in shallow water, but may be taken at depths of up to 200 m.

Eupyrgus scaber Lütken differs from the other species of the genus *E. pacificus* especially in the

shape of the calcareous deposits and the calcareous ring. These differences are however so slight that we have every reason for supposing that future investigations will prove the identity of these two species.

Genus *Paratrochostoma* Heding 1931.

Genotype: *Paratrochostoma spiniferum* n. sp.

Diagnosis: Rather small Molpadids with a short and usually eccentrically placed caudal appendage. Tentacles 15, number of digits two. Calcareous ring with distinct posterior processes, and with peculiarly formed anterior processes (cf. pag. 73 & Pl. V, figs. 20—21). Tentacular ampullae absent, pore-canal large and with a distinct opening on the body-surface, placed posterior to the gonoporus. Longitudinal muscles unpaired and with no retractors. Respiratory trees present and well developed.

Calcareous deposits small tables supplied with long spires with a spiny end.

Remarks: This genus resembles the genus *Trochostoma* in many characters, but the differences in the shape of the calcareous ring and the water-vascular system, as well as in the shape of the longitudinal muscles seem to be so important that it should not only be regarded as a valid genus, but it should even be placed outside the family *Molpadiidae*. As stated above, it is only with much hesitation that it is placed within the same family as *Eupyrigus*, but until we have acquired more knowledge of these interesting forms, it is considered most practical to unite them in a single family.

The genus *Paratrochostoma* is for the present only monotypic, but probably *Trochostoma blakei* Théel will prove to be not only a *Paratrochostoma*, but perhaps synonymous with the genotype. Further some other abyssal forms as *Tr. grossularia* Hérourard and *Tr. grossularia* var. *excentrica* Hérourard, most reasonably may prove to belong to the genus *Paratrochostoma*.

Paratrochostoma spiniferum n. sp.

Pl. IV, figs. 13—14, Pl. V, figs. 20—21.

Localities:

"Ingolf" St. 20 (58°20' N. — 40°48' W.), 3190 m, bottom temp. 1.5°	1	specim.
— St. 36 (61°50' N. — 56°21' W.), 2700 m,	— 1.5°	1	—
— St. 37 (60°17' N. — 54°05' W.), 3230 m,	— 1.4°	3	—

Type specimen: St. 37 sp. 1.

This species seems to be rather small, the two mature specimens at hand, the type and that from St. 20, being only 35 mm and 28 mm long, including the caudal appendage which is about 5 mm long. The three other specimens at hand measure 24 mm, 20 mm and 8 mm. The colour of the specimens in alcohol is pale yellowish-grey, only the smallest specimen (from St. 36) is of the transparent brown colour frequently found in small Synaptids kept in alcohol for many years.

The caudal appendage is about $\frac{1}{5}$ — $\frac{1}{7}$ of the body-length. In all the specimens it is more or less eccentrically placed, being closer to the dorsal than to the ventral side (Pl. IV, fig. 13—14), and on the smallest specimen from St. 37 (37 III) it is not situated at the body-end, but on the posterior part of the dorsal side

(Pl. IV, fig. 13). This feature is rather interesting being used as a character for separating the varieties from *Trochostoma blakei* Théel. Whether it is really a characteristic feature of the species, or it is only due to the contraction of the specimens at hand, cannot be made out with certainty by the preserved material. As in all the specimens at hand the body-wall is distinctly thicker dorsally than ventrally to the caudal appendage, and as this difference is more pronounced in specimens with the caudal appendage situated most eccentrically, I, on my part, ascribe the eccentric position of the caudal appendage to the contraction of the two dorso-lateral longitudinal muscles.

The body-wall is very thin, semi-transparent, and especially in the small specimen from St. 36 densely spinous, due to the long spires of the tables. The longitudinal muscles are unpaired and form rather thin and broad bands, which toward the ends of the body grow narrower and thicker. Anteriorly they are fastened directly to the perforated process of the radials, and posteriorly they reach to the anal end of the caudal appendage.

The number of tentacles is 15. These are much contracted, and nearly totally retracted into the peristome, where they may be hidden in small slits. They are trilobate, each with two digits, one on either side.

The calcareous ring consists of 10 pieces, the radial ones of which are supplied with a large bifurcate prolongation on the posterior side, and two crest-shaped processes on the anterior side. One of the anterior processes, the muscular process, is perforated for the radial nerves. This perforation is relatively small, and very difficult to see, as it is only visible when the ring is traced with "Eau de Javelle". It is situated very close to the tip of the projection, and not in the middle of it, but always distinctly to the one side. The appearance of the calcareous ring (Pl. V, figs. 20—21) is very characteristic, as the tentacle-muscles are fastened between the crest-shaped anterior processes, and not to the exterior side of the ring. As furthermore tentacle-ampullae are absent, the exterior side of the ring is unsculptured and its posterior margin smooth. An interesting and probably very characteristic feature is that the crest-shaped anterior processes of the calcareous ring are, close to their base, more or less hollowed in the sides, a feature which is so marked in the exterior side of the crests of the radial pieces, that when not carefully examined they seem to be perforated (Pl. V, fig. 21). The bifurcate prolongations of the radial pieces are of very nearly the same size and shape.

There is a single polian vesicle, a very long and thin stone-canal with a large madreporite, and a conspicuous pore-canal, which opens close behind the gonoporus. Tentacle ampullae are absent.

The gonads are paired and much branched, and the gonoduct is long. A genital papilla is absent.

The alimentary canal is very voluminous. It makes a large loop, the anterior curve of which reaches close to the calcareous ring. The cloaca is large and gradually tapering into the caudal appendage. The anal opening is surrounded by five radial groups of small papillae. Owing to the contraction of the specimens it is impossible to ascertain the exact number of papillae in each group, but there may be 3—5.

The respiratory trees are large and well developed. The right one forms a single large unbranched bladder, fastened to the body-wall by fine threads. It reaches to the calcareous ring to which it is also fastened. In the type this bladder is very voluminous, and quite like the intestine, being filled with the same grey mud which fills the alimentary canal. In the other specimens there is only mud in the posterior end of the right

respiratory tree, the rest being either a thin canal or a large transparent bladder filled with "water". The left respiratory tree does not reach farther forward than to the two thirds of the length of the specimen, where it is fastened to the body-wall. Its walls are not so smooth as those of the right one, as they are supplied with some few lobular expansions, as well as with a little side-branch. Also the left respiratory tree is, in the type, filled with mud, and in the other specimens either empty or filled with "water".

The calcareous deposits of the body-wall are tables with long spires. There are two different sorts, 1) rather large poly-pore plates with an irregularly spiny spire, and 2) small three-holed plates with an extra long spire supplied with six hooks directed downwards.

In the type the plates from the median part of the body-wall (Textfig. XXI, 2) are rather regularly shaped. Usually they measure about 400—450 μ in length, but some smaller ones may be found. The number of holes is usually 3—6. The shape of the spire-end cannot be ascertained, as it has been broken off in all examined plates. In the posterior end of the body-wall the poly-pore plates are more oblong and supplied with up to 15 holes (Textfig. XXI, 3 & 6). In this part of the body the spires of the tables may be examined, as, although broken off, they are often found lying on the tables (Textfig. XXI, 6). The spires of the poly-pore plates are rather short and supplied with an irregularly spiny end, and those of the three-holed plates (Textfig. XXI, 6 & 12) are exceedingly long and as far as can be ascertained always supplied with 6 large hooks bending downwards. The poly-pore plates in the anterior end of the specimen (Textfig. XXI, 1) are very conspicuous, being more or less rectangular with two horn-shaped projections. They have regularly five holes, and are all arranged at a right angle to the longitudinal axis of the specimen, and with the "horns" at the anterior side. Between these tables, some few with three or usually four holes are found.

The deposits of the caudal appendage (Textfig. XXI, 4) are about 350—400 μ long fusiform tables with a rather short spire; they are, like the anterior ones, arranged at a right angle to the longitudinal axis of the caudal appendage, and slightly curved.

In the anal papillae there are some small 50—80 μ long rods (Textfig. XXI, 5).

The deposits in the specimen from St. 20 agree rather well with those of the type. In the small specimen from St. 36 as well as in 37 II the deposits are more rounded and regularly shaped. In these specimens intermediate stages of the two different sorts of tables are also found (Textfig. XXI, 7—8). In the specimen from St. 36 many quite small three-perforate tables are furthermore found, and while in the type and the large specimen from St. 20 there are more poly-pore plates than three-pore ones, this specimen contains quite as many three-pore as poly-pore plates.

The small specimen with the very eccentric caudal appendage from St. 37, differs somewhat in the shape of the calcareous deposits from the other specimens. The tables from the medial part of the body-wall (Textfig. XXI, 12—14) resemble to some degree the plates from Expl. 37 II, but there are many rod-like tables, some with and others without a distinct spire. In the posterior end of the body, the tables are very varying, often having long and irregularly shaped processes. In the anterior end of the specimen the plates are also very irregularly shaped, and they do not have the conspicuous appearance of the plates from the anterior end of the type-specimen. Thus one should be inclined to regard this specimen as a separate form, but as we

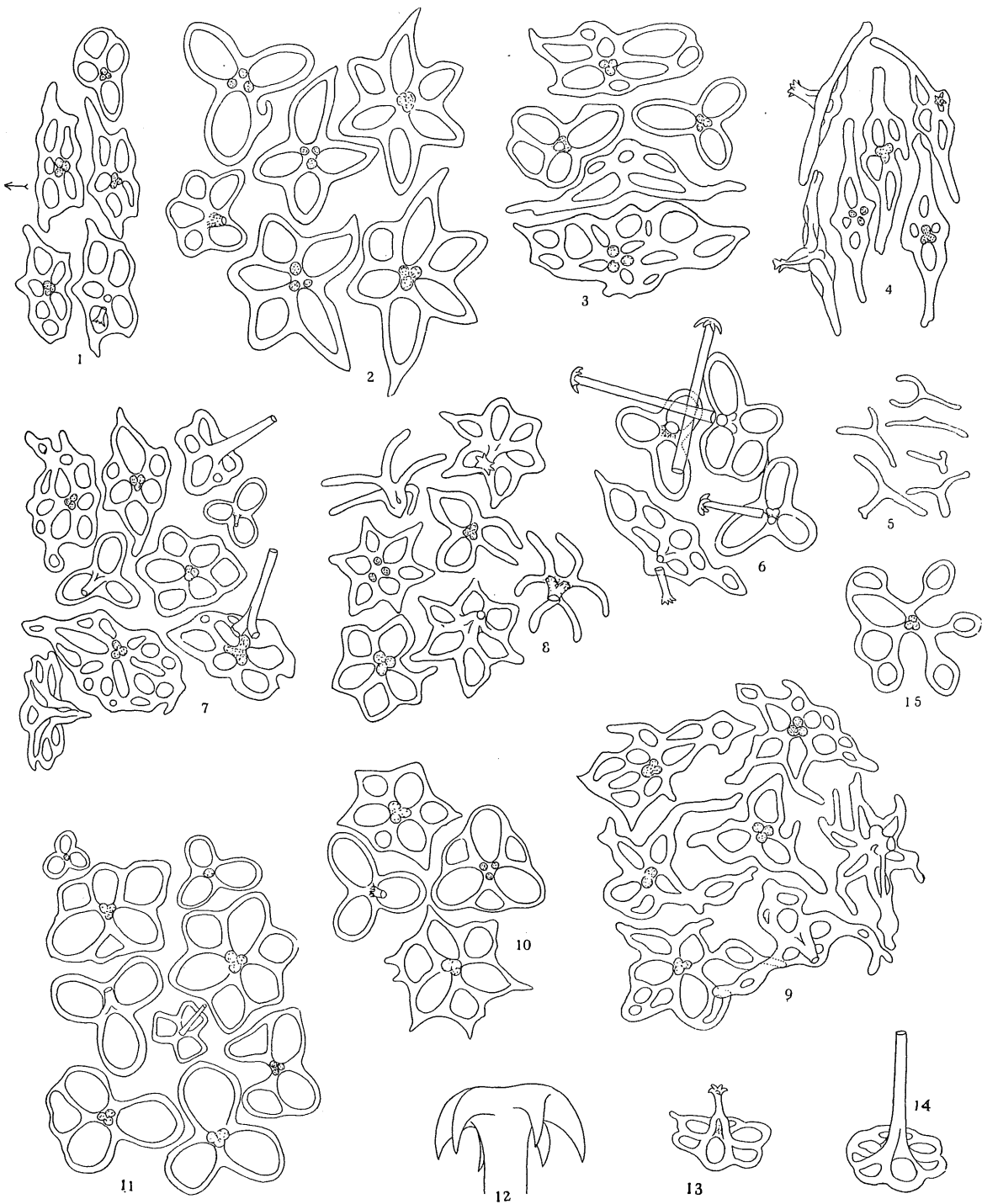

Fig. XXI. *Paratrochostoma spiniferum*. 1—6 the type, 1 from anterior end, 2 from middle, 3 from posterior end, 4 from caudal appendage, 5 from anal teeth, 6 plates from posterior end, showing the spires. 7—9 from cotype Expl. II, 7 from anterior end, 8 from middle, 9 from posterior end. 10 from cotype Expl. III from the middle. 11 from a specimen from St. 36. 12 the end of a normal spire. 13—15 aberrant deposits St. 37 Expl. III.

do not know more than 5 specimens at present, I deem it best to state only the differences between this specimen and the others, awaiting further material for the solution of this problem.

As to the specific determination of the specimens at hand, there is much doubt, as to whether they represent one of the forms described as *Trochostoma blakei*, *Tr. grossularia* and var. *excentrica* of *blakei*. These forms agree exceedingly well in the shape of the calcareous deposits, but until we know with certainty whether the said forms, which may perhaps, as supposed by Mortensen in 1927, be synonymous, belong to the genus *Paratrochostoma* or to *Trochostoma*, we must regard the specimens at hand as representing a separate species.

III. Gephyrothurioidea.

Family Gephyrothuriidae.

Diagnosis: Apedate Holothurians. Respiratory trees one to two. Caudal appendage (always?) absent. Tentacular ampullae absent. Longitudinal muscles unpaired. Ambulacral appendage, besides the tentacles, present either in the shape of large dorsoradial appendages with distinct ampullae, or as small retractile pedicel-like papillae irregularly scattered on the body-surface, or in both sorts.

Remarks: The family *Gephyrothuriidae* was established by Koehler & Vaney in the "Investigator" deep-sea Holothurians, pag. 78, for their monotypic genus *Gephyrothuria*, and there placed among the aspidochirote Holothurians. as Clark in the "Apodous Holothurians" established the genus *Himasthlephora*, which in several respects is rather similar to *Gephyrothuria*, he regarded *Himasthlephora* as a Molpadid, though an aberate one, and consequently transferred the genus *Gephyrothuria* to the *Molpadiidae*, to which family he refers the *Gephyrothuriidae* as a synonym.

That in spite of this he regarded neither *Himasthlephora* nor *Gephyrothuria* as true Molpadids, appears from the fact that he writes pag. 185 that "it might be possible to form a subfamily of *Himasthlephora* and *Gephyrothuria*"; but for the present he thinks it undesirable.

The examination of the specimens described below as *Molpadiodemas acaudum* n. g., n. sp. shows that it is both unnatural and unpractical to regard *Gephyrothuriidae* as a synonym of *Molpadiidae*.

Molpadiodemas n. g.

Genotype: *Molpadiodemas acaudum* n. sp.

Diagnosis: Tentacles normally 20. Longitudinal muscles unpaired. Stone-canal rudimentary, imbedded in the dorsal mesentery between the gonoduct and the oesophagus. Tentacle-ampullae absent. Respiratory trees with a single trunk at the cloaca. Caudal appendage absent. Body-surface, especially towards the ends, supplied with small retractile pedicel-like papillae.

Remarks: The genus *Molpadiodemas* seems to be closely related to the genera *Gephyrothuria* Koehler & Vaney and *Himasthlephora* Clark, but the differences from both of them are so distinct that it must be regarded as an independent genus. The absence of large appendices from the dorsal radial-canal, the single respiratory tree and the large number of tentacles are the main-characters which separate *Molpadiodemas* from the two named genera. Besides, it differs from *Gephyrothuria* in having small pedicel-like papillae as well

as a rudimentary stone-canal, and from *Himasthlephora* in having no caudal appendage and in the gonoduct opening with a pore between the dorsal tentacles, not on a distinct genital-papilla behind the tentacles.

A closer study of the literature dealing with the genera *Gephyrothuria* and *Himasthlephora* shows that the above named differences between these and *Molpadiodemas* are not all quite certain. Koehler & Vaney state that *Gephyrothuria alcocki* has 15 tentacles, but on the next page they write about the calcareous ring, that "dans chaque intervalle entre deux muscles longitudinaux, l'anneau presente trois pointes dirigée en avant". These two statements seem to me to be contradictory, as I quite follow Östergren in assuming that the number of tentacles and the shape of the calcareous ring correspond, so that it may be possible to ascertain the number of tentacles when only the calcareous ring is present and tolerably preserved. In the present case, the "trois pointes" between the insertions of each two longitudinal muscles, form 20 insertions for the tentacle-muscles, according to which one is obliged to assume the real number of tentacles in *Gephyrothuria alcocki* to be 20, and not 15 as stated by Koehler & Vaney. That Koehler & Vaney's statement of the tentacle-number of the small specimens of *Geph. alcocki* may not necessarily be quite reliable is also evident from the examination of the specimens of *Molpadiodemas acaudum* at hand, for in both these large specimens the number of countable tentacles is but 15, but a closer examination shows that the 5 "lacking" tentacles are so retracted into the oral disk, that there is only found 5 narrow slits between the remaining tentacles.

As to *Himasthlephora*, the presence of a caudal appendage in this genus seems rather improbable. Clark himself is by no means sure that the "appendage" mentioned and figured is a real "tail", and he would rather be inclined to regard it as a piece of the intestine, were not the cloaca undisturbed in the examined specimen. Judging from Clark's figure of *Himasthlephora glauca*, I am convinced that the figured "appendage" is nothing but a piece of the intestine.

In discussing the systematic position of *Himasthlephora glauca*, Clark states that the only marked difference between this species and the genus *Gephyrothuria*, is this problematic "tail", and that, were it not present, he would have no doubt in regarding *Himasthlephora* as a synonym of *Gephyrothuria*. In this I cannot agree with Clark. From Clark's figure of the calcareous ring in *Himasthlephora glauca*, it is obvious that his statement as to the number of tentacles in this species is undisputably 15, and thus besides the lacking (rudimentary?) stone-canal indicates a generic difference from *Gephyrothuria*.

In some degree it may seem undesirable to maintain three different genera for these three species, but they differ so much from each other that it would be unnatural to refer them to one and the same genus. Further they are all deviating so much from the real Molpadids, that it seems reasonable to place them in an Order of their own.

***Molpadiodemas acaudum* n. sp.**

Pl, VI, figs. 1—2.

"Ingolf" St. 37 (60°17' N. 54°05' W.), 3230 m, Bottomtemp. 1.4° 2 specim.

The two specimens at hand measure 15 and 20 cm in length by 6 and 8 cm in width. The larger is the type-specimen.

A caudal appendage is lacking. The colour is yellowish white, partly finely dotted with small brown

dots, and towards the ends of the specimens gradually turning into a pale brown. The tentacles are brownish red.

The number of tentacles is exceedingly difficult to make out, as they are placed in several circles, and contracted and retracted in a very high degree. Apparently there are only 15 tentacles; some of which are placed in an inner circle and contracted, or reduced (which is the case cannot be ascertained) to quite rudimentary. The outer circle consists of rather large tentacles, the digits are retracted into their base, just as may be the case with the eyes in common land-snails. The exact number of digits as well as their position cannot be made out, but there appear to be 6—10. A closer examination of the oral disk shows that, besides the mentioned 15 tentacles, there are five narrow slits, which — as it is seen from the examination of the calcareous ring — enclose highly retracted tentacles attached to the latter. Thus the real number of tentacles is 20. The tentacles are all fastened to the calcareous ring, but while it is the rule that the tentacle-muscles fasten directly to the insertions, the muscles in this species end rather sharply, close to the anterior crests of the ring and are only continued by thin transparent tissue.

The bodywall in this species is rather peculiar. In the medial part it is thin, but solid and quite opaque, towards the two ends it is increasing in thickness, to as much as 3—4 mm at the ends. This remarkable thickness is not alone due to contraction, but also to a conspicuous thick layer of cartilaginous-like tissue between the cutis and the transverse-muscles. It is interesting to see that this tissue which in the posterior end of the specimens is thickest closely around the anus, in the anterior end reaches its greatest size somewhat behind the tentacle, in such a way that the oral disk with the tentacles may be quite retracted and hidden. In both specimens is found a very conspicuous sphincter in the thick tissue and in the smaller specimen it is evident that this serves to close the cavity into which the tentacles are retracted. The presence of this sphincter, which is situated outside of the transverse-muscles (cfr. Clark: *Apod. Holoth.*, pag. 143), is undoubtedly a valuable systematic character, but it cannot be used as such before its presence or absence in the related forms is ascertained. On the body-surface there are numerous small 1—2 mm long pedicel-like papillae placed most densely towards the anterior and posterior end. They are evidently contractile and may — though ampullae are absent — be connected with the water-vascular system by fine most likely quite rudimentary canals.

The longitudinal muscles are unpaired; they are in the medial part ca. 1.5 cm broad and ca. 0.5—1 mm thick becoming narrower and thicker towards the ends. Anteriorly they are attached to the radial pieces of the calcareous ring without forming any real retractor, and posteriorly they do not change in shape before reaching the cloaca. Here they set off a small but rather conspicuously placed lamella at a right angle to the muscle, which serves as a retractor ani.

The calcareous ring (Pl. VI) consists of ten pieces. It is rather short and relatively very broad, so that the projections on the anterior side are formed as transverse ridges and not as more or less pointed protuberances. The radial pieces are very large and supplied with four transverse ridges. The two medial ones are nearly meeting and thus form a narrow slit for the passage of the radial nerves. While the ridges of the interradial pieces form perpendicular walls, this is not the case with those of the radial pieces. Here the ridges are so hollowed so as to form a very distinct cavity on the side towards the ends. These cavities of the two outer ridges are so deep that they nearly reach into the mouth of the cavity of the two

medial pieces. The insertions for the tentacular muscles, or, as these, as stated above, do not reach the calcareous ring themselves, for the tissue by which they are connected with the calcareous ring, form large depressions on the anterior side of the calcareous ring between the crests or ridges. On the posterior side of the radial pieces no real bifurcate prolongation is present, but only a blunt and irregular knob. Only on the mid-ventral piece of the large specimen it is faintly bifurcate (Pl. VI).

The ring-canal is unusually voluminous and by five thick and short canals fastened to the posterior knobs or projections of the radial pieces of the calcareous ring. The single polian vesicle is very large. In the larger specimen it is branched into three lobules, but in the other specimen it is undivided. The stone-canal is quite rudimentary and is found imbedded in the net-formed oesophageal part of the dorsal mesentery. It is gradually tapering towards the posterior end of the oesophagus, where it disappears without any madreporite.

The most anterior end of the alimentary canal is formed by a rather narrow oesophagus, surrounded by a reticulate tissue. The intestine forms a large loop. Its walls are rather solid, and along the ventral side of it is seen a rather conspicuous blood-vessel. Also on the dorsal side of the intestine, at the base of the mesentery, there is a large blood-vessel. The dorsal mesentery is very solid and includes besides the blood-vessel and the stone-canal, also the 8 cm long gonoduct. The two other mesenteries are perforated and netshaped, but much larger than the dorsal one, as they may be more than 5 cm broad. They are found in the left dorsal and the right ventral interambulacrum. All the three mesenteries are continuous, and their anterior, as well as their posterior loop is fastened to the body-wall and the longitudinal muscles which they pass.

The two large respiratory trees have a single common trunk, which opens into the right side of the cloaca.

The gonads consist of two small bushy tufts placed rather posteriorly, one on each side of the first descending part of the intestine. They are female in both specimens. The gonoduct is, as stated above, imbedded in the dorsal mesentery. It opens without any papilla between the dorsal tentacles. A close examination of the gonoduct shows that the rather wide gonoduct in the type specimen is closed by a hard conical papilla, perforated by a fine porus. In the other specimen such a hard papilla seems to be absent, but what is actually the case in this specimen can not be made out, as the gonoduct, due to the contraction of the specimen, was somewhat damaged by the dissection.

Calcareous deposits are totally absent, but whether they are really lacking in this species, or they are only dissolved cannot be ascertained, as the examination of the preserving alcohol showed a ph.-concentration of between 6 and 6.5.

There cannot be any doubt that these two specimens represent a good species, which may easily be recognized by the shape of the calcareous ring, the stone-canal and the respiratory trees. Furthermore the presence of small contractile papillae on the body-wall may be a good systematic character.

EXPLANATION OF PLATES.

Plate I.

- Fig. 1. *Oligotrochus vitreus*. An opened specimen showing internal anatomy, especially the connection between the 2nd and 3rd mesenteries.
- 2. *Oligotrochus vitreus*. A typical tentacle.
- 3. *Oligotrochus vitreus*. The off-cut "head" seen from below, showing the voluminous oesophagus, the underside of the calcareous ring and the ring-canal with stone-canal and polian vesicle.
- 4. *Myriotrochus rinkii* Steenstrup. An opened specimen showing internal anatomy with the arrangement of the mesenteries.
- 5. *Myriotrochus rinkii* Steenstrup. A typical outstretched tentacle.
- 6. *Myriotrochus rinkii* Steenstrup. The mid-dorsal and left-dorsal pieces of the calcareous ring with the coalesced madreporite, cleaned in hypochlorite of sodium.
- 7. *Myriotrochus rinkii* Steenstrup. Ventral side of "head" with oesophagus, ring-canal, stone-canal and polian vesicle.
- 8. *Chiridota laevis* (O. Fabricius). Posterior end of the body-wall showing how the longitudinal muscles are fastened to the rectum.
- 9. *Achiridota profunda* n. sp. Anterior end of the type-specimen showing retracted tentacles, calcareous ring, polian vesicle and unbranched gonads.

Plate II.

- Fig. 1—4. *Myriotrochus rinkii* Steenstrup. Left dorsal radial piece of calcareous ring, seen from the exterior side (1), from the tentacles (2), from the interior side (3), and from the side (4).
- 5—8. *Oligotrochus vitreus* Sars. Left dorsal radial piece of calcareous ring seen as in Fig. 1—4.
- 9—12. *Myriotrochus rinkii* Steenstrup. Middorsal interradiar piece of calcareous ring seen from the exterior side (9), from the interior side (10), from the side (11), and from the tentacles (12).
- 13—16. *Oligotrochus vitreus* Sars. Middorsal interradiar piece of calcareous ring seen as in Fig. 9—12.
- 17—19. *Oligotrochus vitreus* Sars. Three ventral pieces of the calcareous ring seen from the exterior side.
- 20—22. *Oligotrochus vitreus* Sars. Three ventral pieces of the calcareous ring of another specimen with a varying development of the posterior processes of the pieces.
- 23—25. *Myriotrochus rinkii* Steenstrup. Three ventral pieces of the calcareous ring seen from the exterior side.

Fig. 26—28. *Oligotrochus vitreus* Sars. Midventral radial piece of calcareous ring seen from the side (26), from the inner side (27), and from the tentacles (28).

— 29—31. *Myriotrochus rinkii* Steenstrup. Midventral piece of calcareous ring, corresponding to Fig. 26—28.

Plate III.

Fig. 1—2. *Oligotrochus vitreus* Sars. Stone-canals with normal (1) and abnormal (2) madreporite.

- 3. *Acanthotrochus mirabilis* Dan. & Kor. A part of the madreporite drawn with a rather high magnification.
- 4. *Acanthotrochus mirabilis* Dan. & Kor. A bit of the madreporite in xylol, drawn with a very high magnification ($500\times$).
- 5. *Acanthotrochus mirabilis* Dan. & Kor. The three left dorsolateral pieces of the calcareous ring.
- 6. *Acanthotrochus mirabilis* Dan. & Kor. Left ventrolateral radial and two dorsolateral interradials seen somewhat from below.
- 7. *Acanthotrochus mirabilis* Dan. & Kor. Medioventral and left ventrolateral pieces of calcareous ring.
- 8. *Acanthotrochus mirabilis* Dan. & Kor. Three dorsal pieces of a calcareous ring.
- 9. *Acanthotrochus mirabilis* Dan. & Kor. A tentacle.
- 10. *Acanthotrochus mirabilis* Dan. & Kor. Part of large wheel showing a beginning dissolution, and the manner in which the acid attacks the wheel.
- 11. *Chiridota pellucida* (Vahl). Calcareous ring.
- 12. *Chiridota spirourna* n. sp. Calcareous ring.
- 13. *Chiridota laevis* (O. Fabr.). Calcareous ring.
- 14. *Achiridota ingolfi* n. sp. Calcareous ring.
- 15. *Trochoderma elegans* Théel. An opened specimen showing the internal anatomy, especially the unbranched gonads.
- 16—18. *Trochoderma elegans* Théel. Pieces of the calcareous ring.
- 19. *Ankyroderma jeffreysii* Dan. & Kor. Anterior part of dorsal interambulacrum seen from the inner side, showing the arrangement of the gonoduct, the stone-canal with the madreporite and the anterior part of the "axial" organ r. c. ring-canal ax. "axial" organ s. stone-canal g. gonoduct.

Plate IV.

Fig. 1. *Trochostoma thomsonii* Dan. & Kor. The anal opening and its surrounding papillae.

- 2. *Trochostoma thomsonii* Dan. & Kor. The pseudo-retractor-muscle in a contracted specimen.
- 3—4. *Trochostoma thomsonii* Dan. & Kor. Varying shape of the rectal pieces of the intestine.
- 5. *Trochostoma thomsonii* Dan. & Kor. An uncontracted "tail".
- 6. *Trochostoma thomsonii* Dan. & Kor. A retracted tentacle in its sheath.
- 7—8. *Ankyroderma jeffreysii* Dan. & Kor. Stone-canal with madreporite seen from different sides.
- 9. *Haplodactyla albicans* (Théel).
- 10. *Eupyrgus scaber* Lütken.

- Fig. 11. *Eupyrgus scaber* Lütken. Three anal teeth dissected out.
 — 12. *Ankyroderma affine* Dan. & Kor.
 — 13—14. *Paratrochostoma spiniferum* n. sp. Two specimens from St. 37.

Plate V.

- Fig. 1. *Trochostoma thomsonii* Dan. & Kor. Midventral radial and right ventral interrarial.
 — 2. *Trochostoma thomsonii* Dan. & Kor. Left dorsal radial and interrarial.
 — 3. *Trochostoma thomsonii* Dan. & Kor. Mid-dorsal interrarial.
 — 4—5. *Trochostoma thomsonii* Dan. & Kor. Mid-ventral (4) and left dorsal radial and interrarial of specimen from St. 37.
 — 6—7. *Trochostoma boreale* Sars. Dorsal (6) and ventral (7) pieces of calcareous ring.
 — 8. *Trochostoma arcticum* (v. Marenzeller) Right dorsal radial with adjoining middorsal and laterodorsal interradians.
 — 9. *Eumolpadia asaphes* n. sp. Right ventral radial with 2 adjoining interradians.
 — 10. *Eumolpadia violacea* (Studer)
 — 11. *Paramolpadia diploa* Heding.
 — 12. *Paramolpadia capensis* Heding.
 — 13. *Molpadia spinosa* (Ludwig).
 — 14. *Ankyroderma jeffreysii* Dan. & Kor.
 — 15. *Ankyroderma affine* Dan. & Kor.
 — 16. *Ankyroderma groenlandica* (Mrtsn.) Type.
 — 17. *Haplodactyla albicans* Théel.
 — 18—19. *Caudina arenata* (Gould). Two different specimens.
 — 20—21. *Paratrochostoma spiniferum* n. sp. from the exterior side (20) and from the side of the crests (21).

Plate VI.

- Fig. 1. *Molpadiodemas acaudum* n. sp.
 — 2. *Molpadiodemas acaudum* n. sp. Radial and interrarial.

Plate VII.

- Fig. 1. *Paramolpadia diploa* Heding.
 — 2. *Eumolpadia asaphes* n. sp.
 — 3. *Eumolpadia violacea* (Studer).
 — 4. *Ankyroderma jeffreysii* Dan. & Kor. The opening for the stone-canal and its surroundings.

Plate VIII.

Semidiagrammatic figures of the mesenterial course in the following Molpadids:

1. *Trochostoma thomsonii* Dan. & Kor. The figure is from one of the "Godthaab" specimens, and deviates in details a little from the description p. 54, which is based on the "Ingolf" and "M. Sars" specimens.

2. *Trochostoma arcticum* (v. Marenzeller).
 3. *Trochostoma boreale* (Sars).
 4. *Eumolpadia violacea* Studer.
 5. *Ankyroderma jeffreysii*. Dan. & Kor.
 6. *Ankyroderma affine* Dan. & Kor.
 7. *Ankyroderma affine* var. *groenlandica* (Mrtsn.) Type specimen.
 8. *Paramolpadia diploa* Heding.
 9. *Caudina arenata* (Gould).
 10. *Haplodactyla albicans* (Théel).
 11. *Eupyrgus scaber* Lütken.
 12. *Molpadiodemas acaudum* n. sp.
-



1

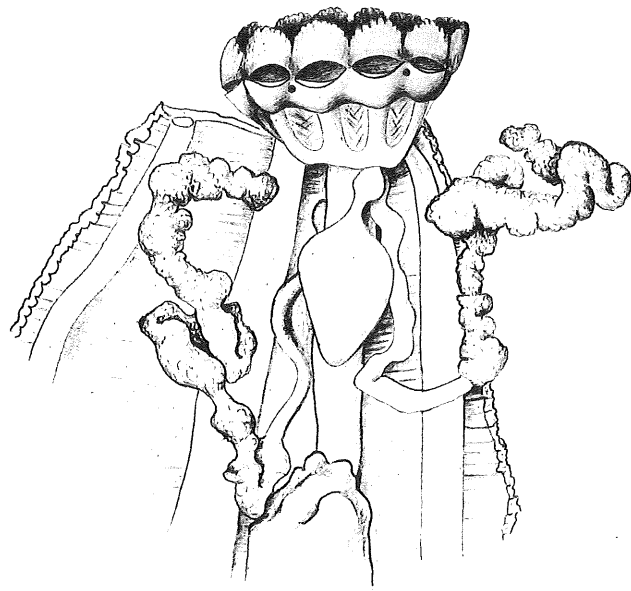

9



4

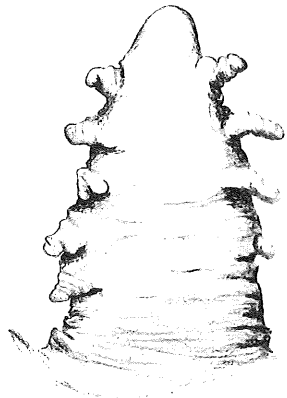

2

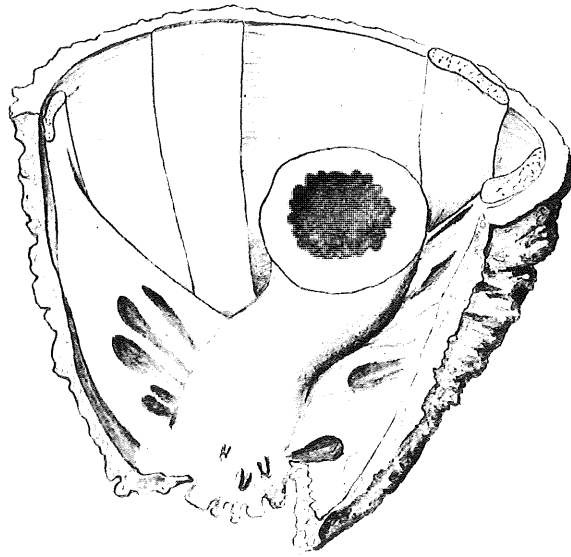

8



5

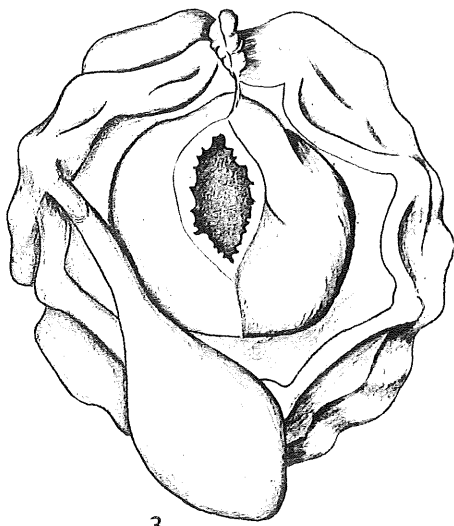

3

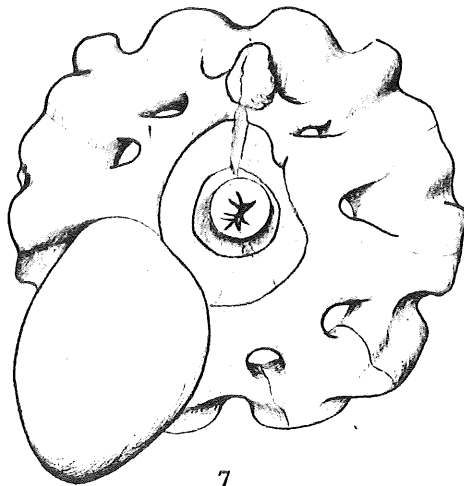

7

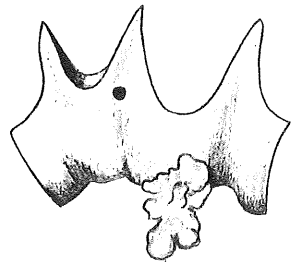

6

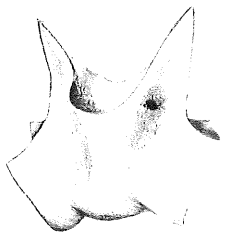

1

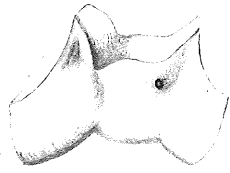

5

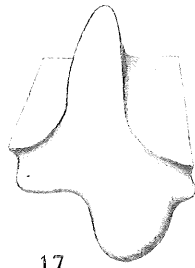

17

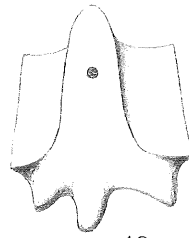

18

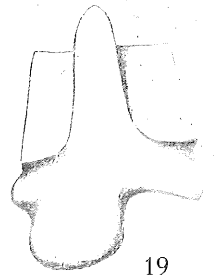

19



2

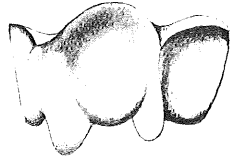

6

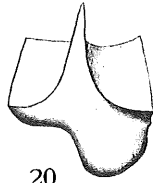

20



21

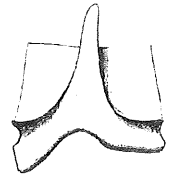

22



3



7

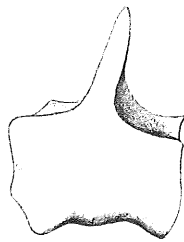

23

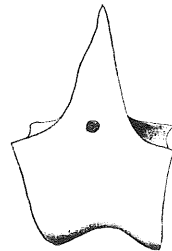

24

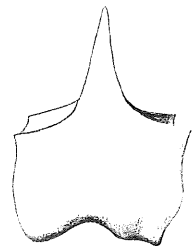

25

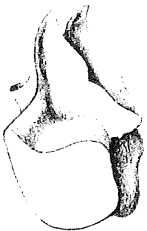

4

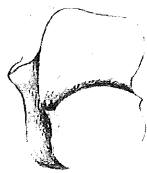

8

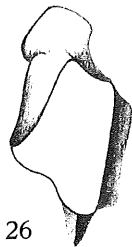

26

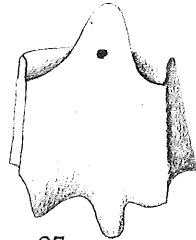

27

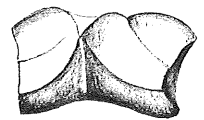

28

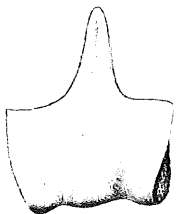

9



13

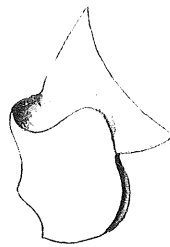

11

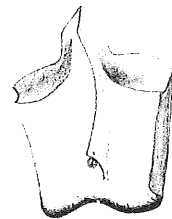

29

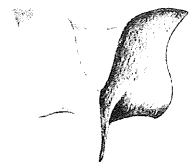

30



12

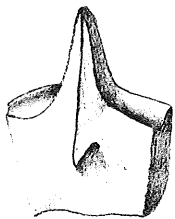

10

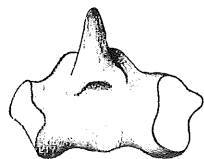

14

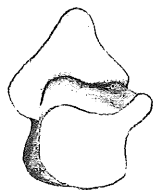

15

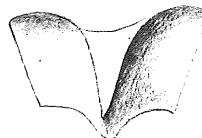

16



31

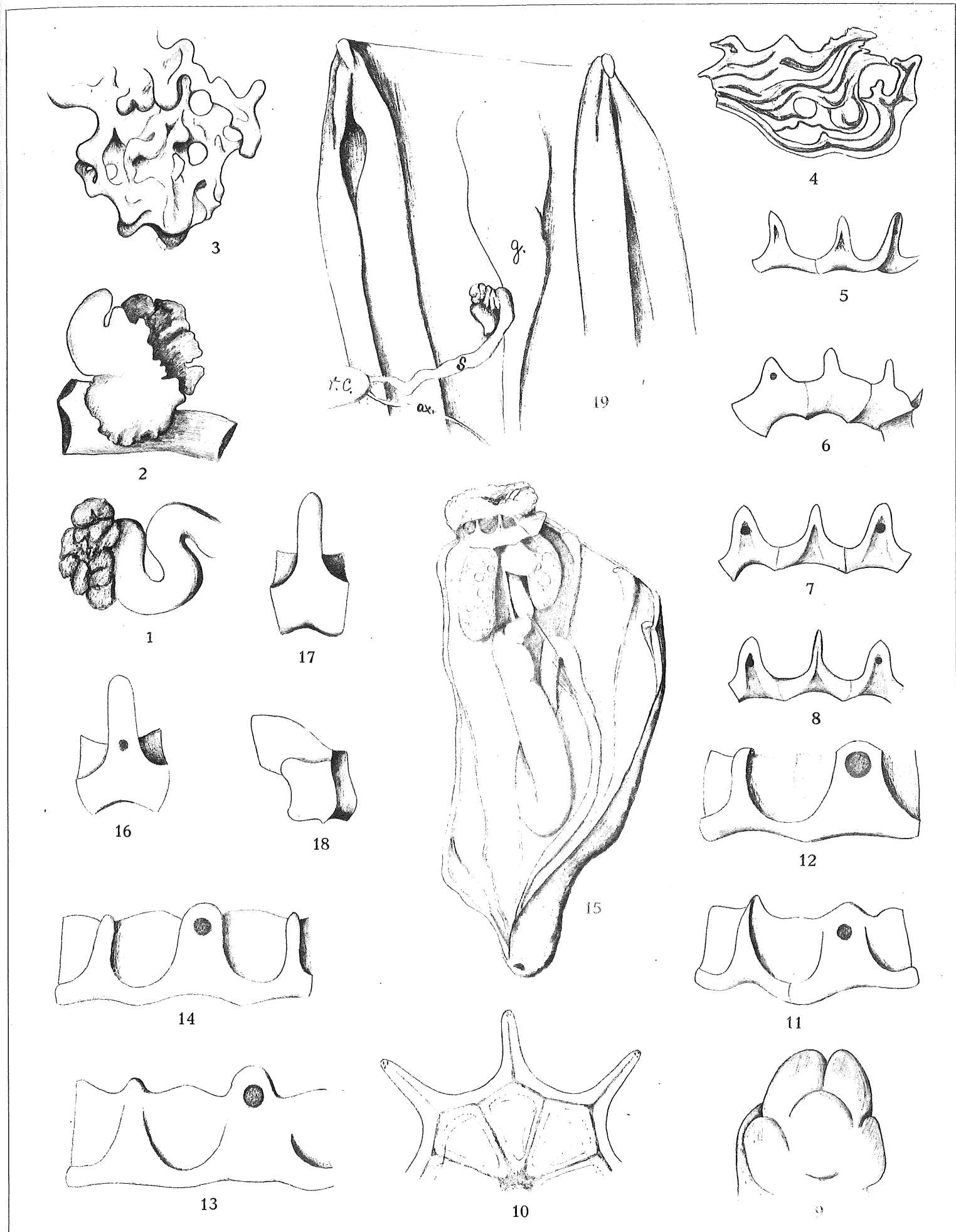

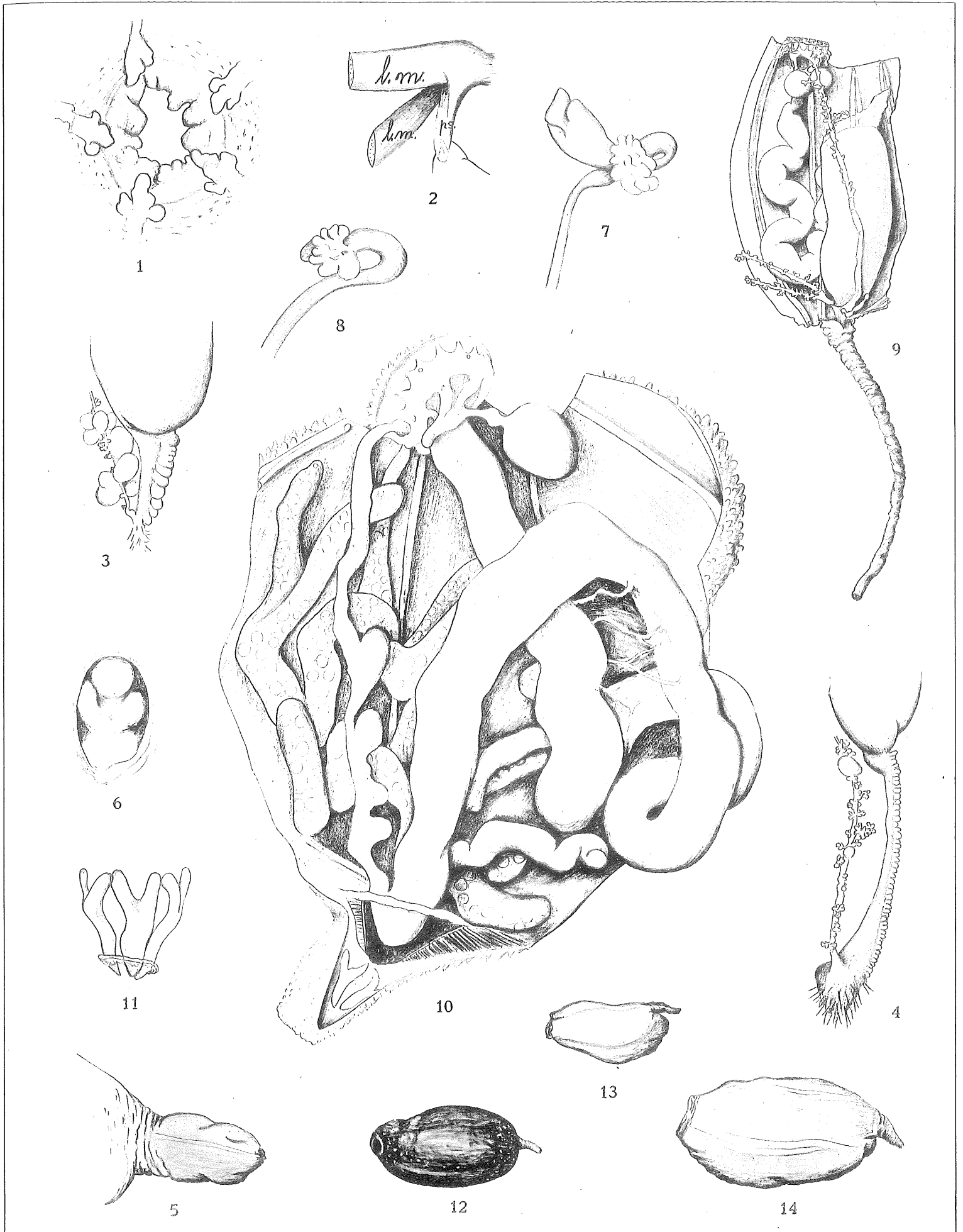



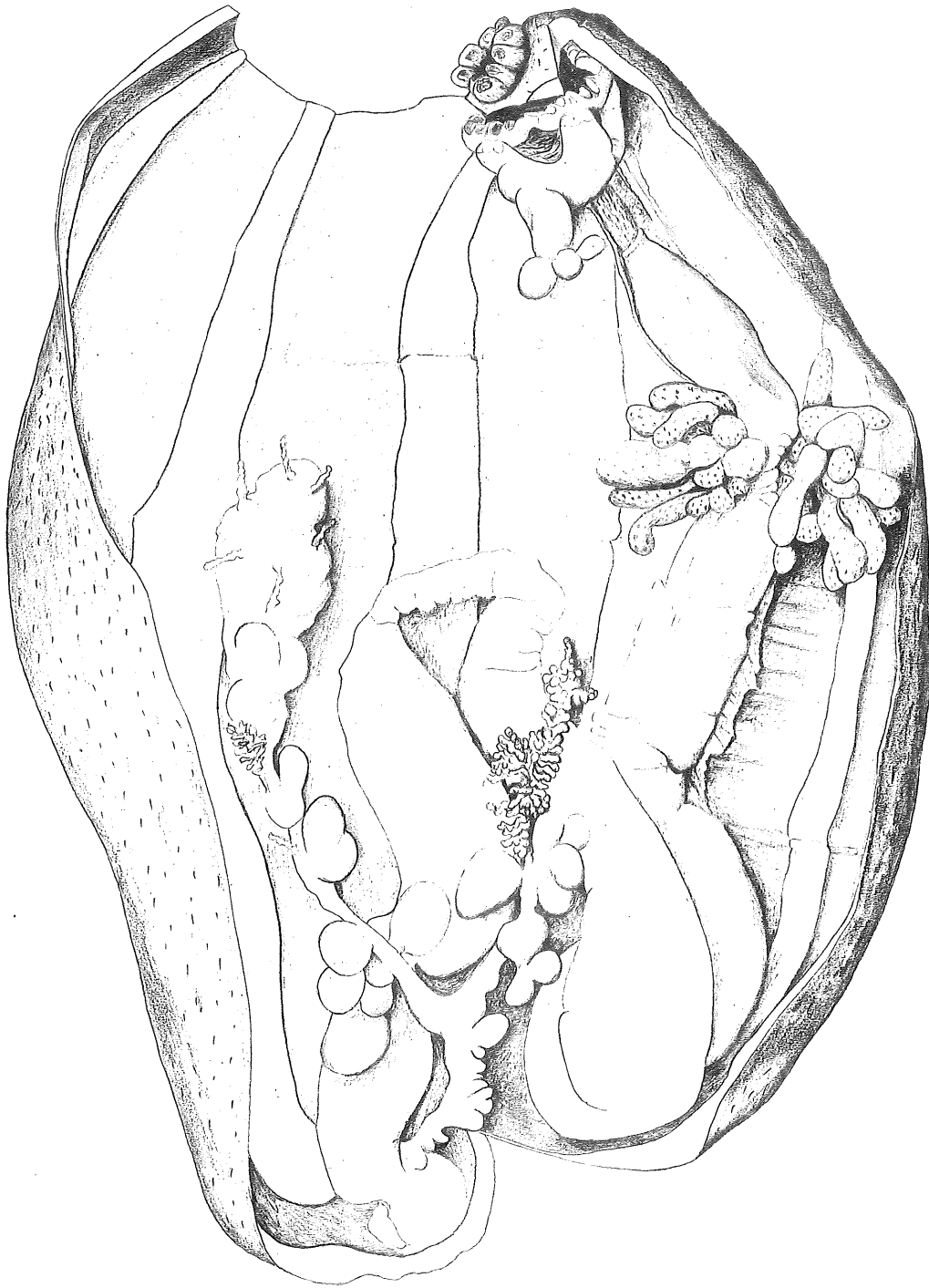

1

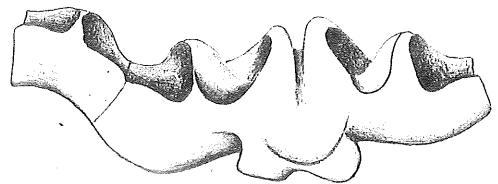

2



1

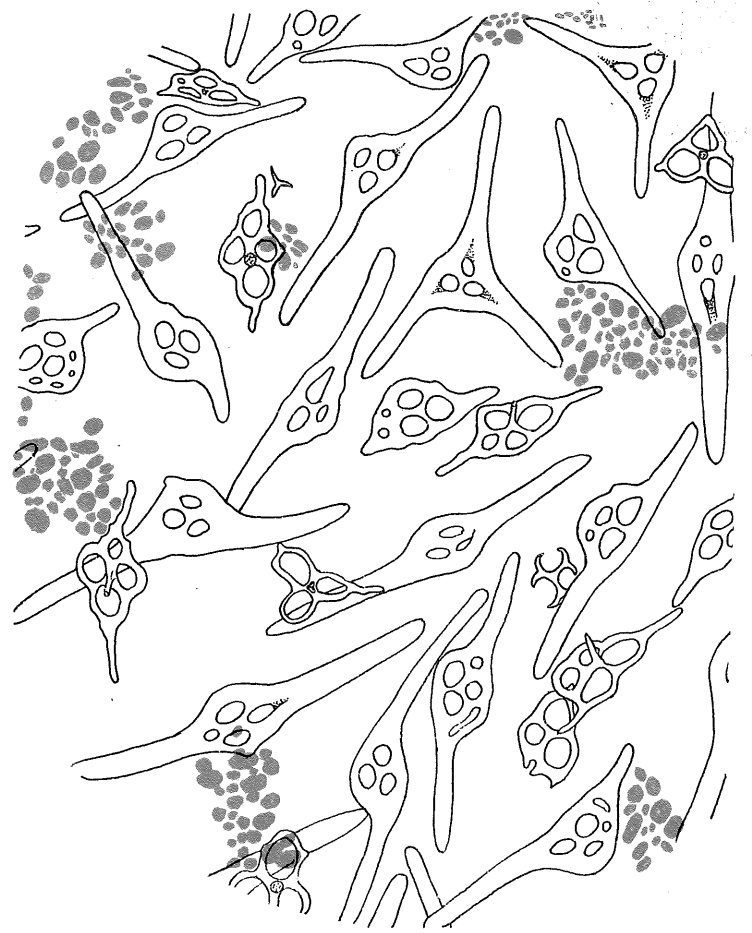

2

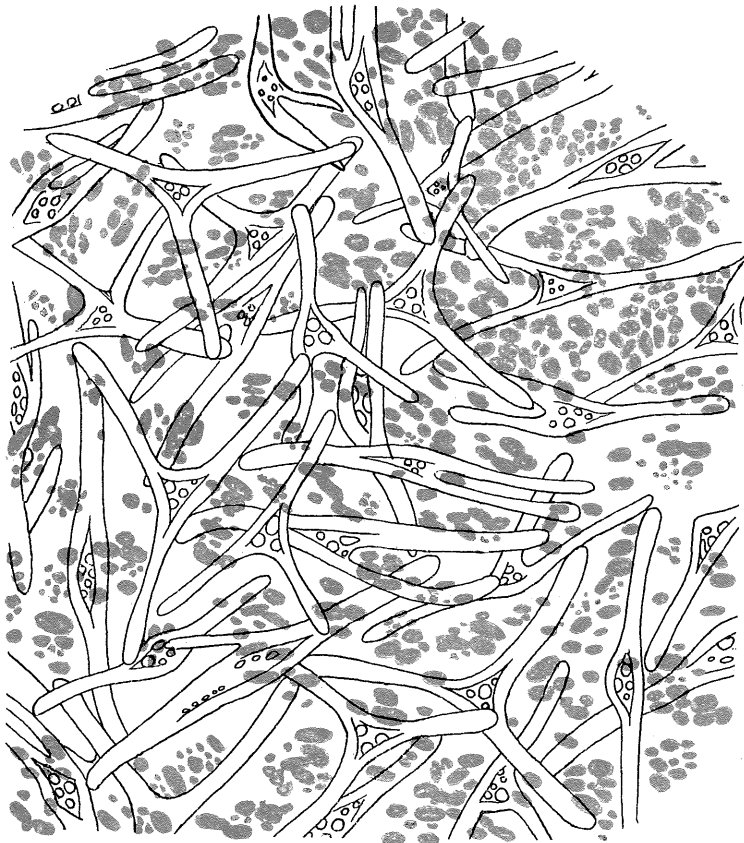

3

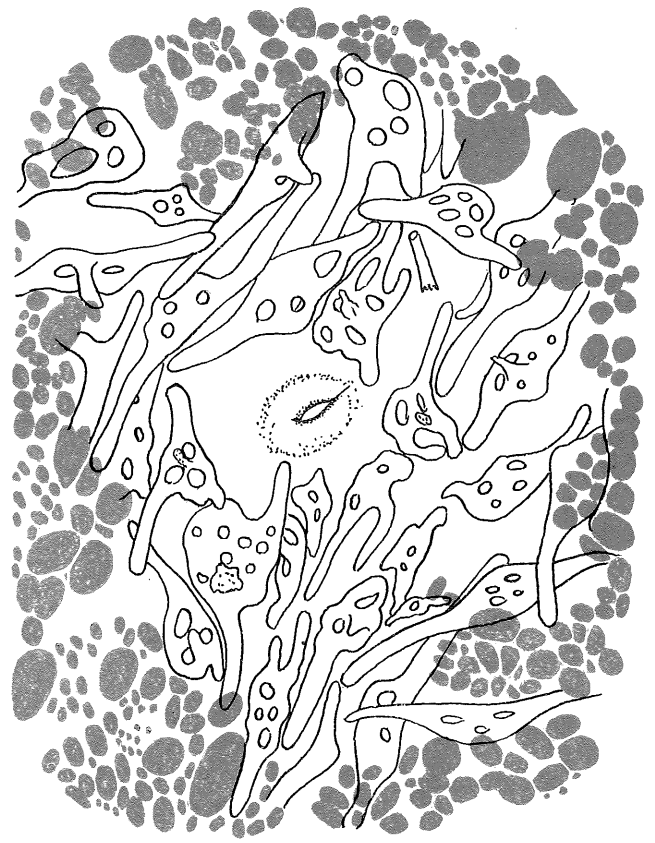

4

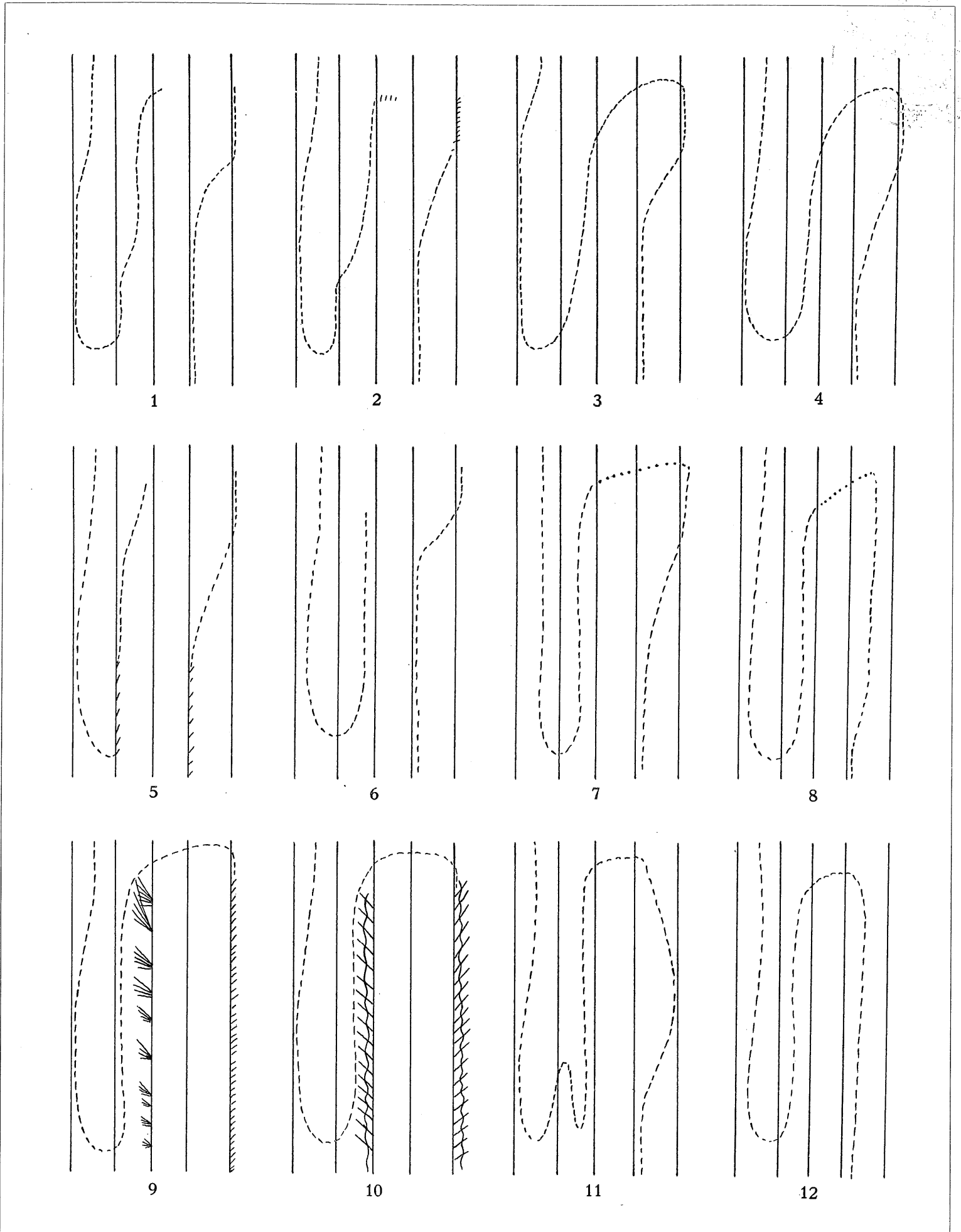

THE INGOLF-EXPEDITION

1895—1896.

THE LOCALITIES, DEPTHS, AND BOTTOMTEMPERATURES OF THE STATIONS

Station Nr.	Lat. N.	Long. W.	Depth in Danish fathoms	Bottom-temp.	Station Nr.	Lat. N.	Long. W.	Depth in Danish fathoms	Bottom-temp.	Station Nr.	Lat. N.	Long. W.	Depth in Danish fathoms	Bottom-temp.
1	62° 30'	8° 21'	132	7°2	24	63° 06'	56° 00'	1199	2°4	45	61° 32'	9° 43'	643	4°17
2	63° 04'	9° 22'	262	5°3	25	63° 30'	54° 25'	582	3°3	46	61° 32'	11° 36'	720	2°40
3	63° 35'	10° 24'	272	0°5		63° 51'	53° 03'	136		47	61° 32'	13° 40'	950	3°23
4	64° 07'	11° 12'	237	2°5	26	63° 57'	52° 41'	34	0°6	48	61° 32'	15° 11'	1150	3°17
5	64° 40'	12° 09'	155			64° 37'	54° 24'	109		49	62° 07'	15° 07'	1120	2°91
6	63° 43'	14° 34'	90	7°0	27	64° 54'	55° 10'	393	3°8	50	62° 43'	15° 07'	1020	3°13
7	63° 13'	15° 41'	600	4°5	28	65° 14'	55° 42'	420	3°5	51	64° 15'	14° 22'	68	7°32
8	63° 56'	24° 40'	136	6°0	29	65° 34'	54° 31'	68	0°2	52	63° 57'	13° 32'	420	7°87
9	64° 18'	27° 00'	295	5°8	30	66° 50'	54° 28'	22	1°05	53	63° 15'	15° 07'	795	3°08
10	64° 24'	28° 50'	788	3°5	31	66° 35'	55° 54'	88	1°6	54	63° 08'	15° 40'	691	3°9
11	64° 34'	31° 12'	1300	1°6	32	66° 35'	56° 38'	318	3°9	55	63° 33'	15° 02'	316	5°9
12	64° 38'	32° 37'	1040	0°3	33	67° 57'	55° 30'	35	0°8	56	64° 00'	15° 09'	68	7°57
13	64° 47'	34° 33'	622	3°0	34	65° 17'	54° 17'	55		57	63° 37'	13° 02'	350	3°4
14	64° 45'	35° 05'	176	4°4	35	65° 16'	55° 05'	362	3°6	58	64° 25'	12° 09'	211	0°8
15	66° 18'	25° 59'	330	—0°75	36	61° 50'	56° 21'	1435	1°5	59	65° 00'	11° 16'	310	0°1
16	65° 43'	20° 58'	250	6°1	37	60° 17'	54° 05'	1715	1°4	60	65° 09'	12° 27'	124	0°9
17	62° 49'	26° 55'	745	3°4	38	59° 12'	51° 05'	1870	1°3	61	65° 03'	13° 06'	55	0°4
18	61° 44'	30° 29'	1135	3°0	39	62° 00'	22° 38'	865	2°9	62	63° 18'	19° 12'	72	7°92
19	60° 29'	34° 14'	1566	2°4	40	62° 00'	21° 36'	845	3°3	63	62° 40'	19° 05'	800	4°0
20	58° 20'	40° 48'	1695	1°5	41	61° 39'	17° 10'	1245	2°0	64	62° 06'	19° 00'	1041	3°1
21	58° 01'	44° 45'	1330	2°4	42	61° 41'	10° 17'	625	0°4	65	61° 33'	19° 00'	1089	3°0
22	58° 10'	48° 25'	1845	1°4	43	61° 42'	10° 11'	645	0°05	66	61° 33'	20° 43'	1128	3°3
23	60° 43'	56° 00'			44	61° 42'	9° 36'	545	4°8	67	61° 30'	22° 30'	975	3°0

Only the
Plankton-Net
used

Station Nr.	Lat. N.	Long. W.	Depth in Danish fathoms	Bottom-temp.	Station Nr.	Lat. N.	Long. W.	Depth in Danish fathoms	Bottom-temp.	Station Nr.	Lat. N.	Long. W.	Depth in Danish fathoms	Bottom-temp.
68	62° 06'	22° 30'	843	3°4	92	64° 44'	32° 52'	976	1°4	118	68° 27'	8° 20'	1060	-1°0
69	62° 40'	22° 17'	589	3°9	93	64° 24'	35° 14'	767	1°46	119	67° 53'	10° 19'	1010	-1°0
70	63° 09'	22° 05'	134	7°0	94	64° 56'	36° 19'	204	4°1	120	67° 29'	11° 32'	885	-1°0
71	63° 46'	22° 03'	46			65° 31'	30° 45'	213		121	66° 59'	13° 11'	529	-0°7
72	63° 12'	23° 04'	197	6°7	95	65° 14'	30° 39'	752	2°1	122	66° 42'	14° 44'	115	1°8
73	62° 58'	23° 28'	486	5°5	96	65° 24'	29° 00'	735	1°2	123	66° 52'	15° 40'	145	2°0
74	62° 17'	24° 36'	695	4°2	97	65° 28'	27° 39'	450	5°5	124	67° 40'	15° 40'	495	-0°6
	61° 57'	25° 35'	761		98	65° 38'	26° 27'	138	5°9	125	68° 08'	16° 02'	729	-0°8
	61° 28'	25° 06'	829		99	66° 13'	25° 53'	187	6°1	126	67° 19'	15° 52'	293	-0°5
75	61° 28'	26° 25'	780	4°3	100	66° 23'	14° 02'	59	0°4	127	66° 33'	20° 05'	44	5°6
76	60° 50'	26° 50'	806	4°1	101	66° 23'	12° 05'	537	-0°7	128	66° 50'	20° 02'	194	0°6
77	60° 10'	26° 59'	951	3°6	102	66° 23'	10° 26'	750	-0°9	129	66° 35'	23° 47'	117	6°5
78	60° 37'	27° 52'	799	4°5	103	66° 23'	8° 52'	579	-0°6	130	63° 00'	20° 40'	338	6°55
79	60° 52'	28° 58'	653	4°4	104	66° 23'	7° 25'	957	-1°1	131	63° 00'	19° 09'	698	4°7
80	61° 02'	29° 32'	935	4°0	105	65° 34'	7° 31'	762	-0°8	132	63° 00'	17° 04'	747	4°6
81	61° 44'	27° 00'	485	6°1	106	65° 34'	8° 54'	447	-0°6	133	63° 14'	11° 24'	230	2°2
82	61° 55'	27° 28'	824	4°1		65° 29'	8° 40'	466		134	62° 34'	10° 26'	299	4°1
83	62° 25'	28° 30'	912	3°5	107	65° 33'	10° 28'	492	-0°3	135	62° 48'	9° 48'	270	0°4
	62° 36'	26° 01'	472		108	65° 30'	12° 00'	97	1°1	136	63° 01'	9° 11'	256	4°8
	62° 36'	25° 30'	401		109	65° 29'	13° 25'	38	1°5	137	63° 14'	8° 31'	297	-0°6
84	62° 58'	25° 24'	633	4°8	110	66° 44'	11° 33'	781	-0°8	138	63° 26'	7° 56'	471	-0°6
85	63° 21'	25° 21'	170		111	67° 14'	8° 48'	860	-0°9	139	63° 36'	7° 30'	702	-0°6
86	65° 03' ₀	23° 47' ₀	76		112	67° 57'	6° 44'	1267	-1°1	140	63° 29'	6° 57'	780	-0°9
87	65° 02' ₃	23° 56' ₂	110		113	69° 31'	7° 06'	1309	-1°0	141	63° 22'	6° 58'	679	-0°6
88	64° 58'	24° 25'	76	6°9	114	70° 36'	7° 29'	773	-1°0	142	63° 07'	7° 05'	587	-0°6
89	64° 45'	27° 20'	310	8°4	115	70° 50'	8° 29'	86	0°1	143	62° 58'	7° 09'	388	-0°4
90	64° 45'	29° 06'	568	4°4	116	70° 05'	8° 26'	371	-0°4	144	62° 49'	7° 12'	276	1°6
91	64° 44'	31° 00'	1236	3°1	117	69° 13'	8° 23'	1003	-1°0					

THE DANISH INGOLF-EXPEDITION.

HITHERTO PUBLISHED:

1899.	Vol. I,	Part I.	1. Report of the Voyage by <i>C. F. Wandel</i> (1 plate)	} Kr. 25,00 (Sh. 30)
			2. Hydrography by <i>Martin Knudsen</i> (34 plates) . . .	
1900.	—	Part II.	3. The deposits of the sea-bottom by <i>O. B. Boeggild</i> (7 charts)	} - 8,00 (- 11)
			4. Current-bottles by <i>C. F. Wandel</i> (1 plate)	
1899.	Vol. II,	Part I.	The ichthyological results by <i>Chr. Lütken</i> (4 plates) . .	} - 13,00 (- 18)
1899.	—	Part II.	On the Appendices genitales (Claspers) in the Green- land Shark, <i>Somniosus microcephalus</i> (Bl. Schn.), and other Selachians by <i>Hector F. E. Jungersen</i> (6 plates)	
1900.	—	Part III.	Nudibranchiate Gasteropoda by <i>R. Bergh</i> (5 plates)	- 4,75 (- 7)
1904.	—	Part IV.	The North-European and Greenland Lycodinae by <i>Adolf Severin Jensen</i> (10 plates)	- 9,75 (- 13)
1912.	—	Part V.	Lamellibranchiata, Part I, by <i>Ad. S. Jensen</i> (4 plates and 5 figures in the text)	- 8,00 (- 11)
1923.	—	Part VI.	Ascidacea, Part I. Zugleich eine Übersicht über die arktische und boreale Ascidiënfauna auf tiergeographischer Grundlage von <i>R. Hartmeyer</i> . (1 Tafel und 35 Textfiguren)	- 20,00 (- 24)
1924.	—	Part VII.	Ascidacea, Part II. Zugleich eine Übersicht über die arktische und boreale Ascidiënfauna auf tiergeographischer Grundlage von <i>R. Hartmeyer</i> (45 Textfiguren)	- 15,00 (- 18)
1899.	Vol. III,	Part I.	Pycnogonidæ by <i>Fr. Meinert</i> (5 plates)	- 6,00 (- 9)
1908.	—	Part II.	Crustacea Malacostraca, I: Decapoda, Euphausiacea, Mysidacea by <i>H. J. Hansen</i> (5 plates)	- 8,00 (- 11)
1913.	—	Part III.	Crustacea Malacostraca, II: Tanaidacea by <i>H. J.</i> <i>Hansen</i> (12 plates)	- 13,00 (- 18)
1915.	—	Part IV.	Copepoda I. Calanoida. Amphiscandria by <i>Carl With</i> (8 plates, 422 textfigures)	- 15,00 (- 18)
1916.	—	Part V.	Crustacea Malacostraca, III: Isopoda by <i>H. J. Hansen</i> (16 plates)	- 20,00 (- 24)
1920.	—	Part VI.	Crustacea Malacostraca, IV: Cumacea and Nebaliacea by <i>H. J. Hansen</i> . (4 plates)	- 9,50 (- 13)
1923.	—	Part VII.	Crustacea Copepoda, II: Copepoda Parasita and Hemiparasita by <i>H. J. Hansen</i> (5 plates)	- 8,00 (- 11)
1923.	—	Part VIII.	Crustacea Malacostraca, V: Amphipoda. I. by <i>K. Stephensen</i> (22 figures and 15 charts)	- 6,00 (- 9)
1925.	—	Part IX.	Crustacea Malacostraca, VI: Amphipoda. II. by <i>K. Stephensen</i> (31 figures and 16 charts)	- 6,00 (- 9)
1928.	—	Part X.	Rhizocephala of the North Atlantic Region by <i>H. Boschma</i> (17 figures and 1 map in the text)	- 3,50 (- 5)
1931.	—	Part XI.	Crustacea Malacostraca, VII: Amphipoda. III. by <i>K. Stephensen</i> (28 figures and 20 charts)	- 8,00 (- 11)
1903.	Vol. IV,	Part I.	Echinoidea, Part I, by <i>Th. Mortensen</i> (21 plates) . . .	- 20,00 (- 24)
1907.	—	Part II.	Echinoidea, Part II, by <i>Th. Mortensen</i> (19 plates) .	- 19,00 (- 23)
1914.	—	Part III.	Chaetognaths by <i>R. von Ritter-Záhony</i>	- 0,50 (- 1)
1917.	—	Part IV.	Annelids I, by <i>Hjalmar Ditlevsen</i> (6 plates and 24 figures in the text)	- 6,50 (- 9)
1923.	—	Part V.	Crinoidea by <i>Austin H. Clark</i> (58 figures in the text)	- 6,00 (- 9)
1926.	—	Part VI.	Free-living Nematodes by <i>Hjalmar Ditlevsen</i> (15 plates)	- 23,00 (- 28)
1930.	—	Part VII.	Priapulidæ and Sipunculidæ by <i>Elise Wesenberg-Lund</i> (6 plates)	- 10,50 (- 14)
1933.	—	Part VIII.	Ophiuroidea by <i>Th. Mortensen</i> (3 plates and 52 figures in the text)	- 13,00 (- 18)
1935.	—	Part IX.	Holothurioidea by <i>S. G. Heding</i> (8 plates and 21 figures in the text)	- 15,00 (- 18)

1904.	Vol. V,	Part I. Pennatulida by <i>Hector F. E. Jungersen</i> (3 plates)...	Kr. 6,50 (Sh. 9)
1912.	—	Part II. Ctenophora by <i>Th. Mortensen</i> (10 plates and 15 figures in the text).....	- 10,50 (- 14)
1912.	—	Part III. Ceriantharia by <i>Oskar Carlgren</i> (5 plates and 16 figures in the text).....	- 6,00 (- 9)
1913.	—	Part IV. Zoantharia by <i>Oskar Carlgren</i> (7 plates and 6 figures in the text).....	- 7,00 (- 10)
1914.	—	Part V. Stylasteridae by <i>Hjalmar Broch</i> (5 plates and 7 figures in the text).....	- 4,75 (- 7)
1916.	—	Part VI. Hydroida, Part I, by <i>Hjalmar Broch</i> (2 plates and 20 figures in the text).....	- 4 75 (- 7)
1918.	—	Part VII. Hydroida, Part II, by <i>Hjalmar Broch</i> (1 plate and 95 figures in the text).....	- 12,00 (- 16)
1919.	—	Part VIII. Medusæ, Part I, Leptomedusæ by <i>P. L. Kramp</i> (5 plates, 17 figures in the text, and 14 maps).....	- 12,50 (- 17)
1921.	—	Part IX. Actiniaria, Part I, by <i>Oskar Carlgren</i> (4 plates and 210 figures in the text).....	- 20,00 (- 24)
1926.	—	Part X. Medusæ, Part II, Anthomedusæ by <i>P. L. Kramp</i> (2 plates, 40 figures in the text, and 18 maps).....	- 10,50 (- 14)
1927.	—	Part XI. Anthomastus by <i>Hector F. E. Jungersen</i> (1 plate, 3 figures and 1 map in the text).....	- 1,50 (- 3)
1902.	Vol. VI,	Part I. Porifera, Part I, Homorrhaphidæ and Heterorrhaphidæ by <i>Will. Lundbeck</i> (19 plates).....	- 17,00 (- 22)
1905.	—	Part II. Porifera, Part 2, Desmacidonidæ (Pars) by <i>Will. Lundbeck</i> (20 plates).....	- 20,50 (- 25)
1910.	—	Part III. Porifera, Part 3, Desmacidonidæ (Pars) by <i>Will. Lundbeck</i> (11 plates).....	- 12,00 (- 16)
1928.	—	Part IV. Hexactinellida by <i>Maurice Burton</i> (9 figures in the text).....	- 1,50 (- 3)